



MAGNUM EB

“BATTERY POWERED”

BASIC OPERATION, MAINTENANCE & TROUBLESHOOTING MANUAL



EUREKA S.r.l.

Via dell'Industria 32, 35013 CITTADELLA (PD) ITALY

Tel. ++39 - 049 - 9481800

Fax. ++39 -049 - 9481899

INTERNET: www.eurekasweepers.com E-MAIL: info@eurekasweepers.com

TABLE OF CONTENTS

<u>TOPIC</u>	<u>PAGE</u>
1. INTRODUCTION	3
2. GENERAL NOTE	3
3. WARNINGS AND RECOMMENDATIONS	3
4. THE DASHBOARD	4
5. BASIC OPERATING CONTROLS	5
6. DANGER AND OBLIGATION SYMBOLS	5
7. USE AND MAINTENANCE OF THE SWEEPER	6
• <i>STARTING THE ENGINE</i>	6
• <i>STARTING THE FUNCTIONS</i>	6
• <i>TURNING OFF THE MACHINE</i>	6
• <i>MOVING THE MACHINE</i>	6
• <i>PARKING BRAKE</i>	6
• <i>SERVICE BRAKE</i>	6
• <i>EMERGENCY BRAKE</i>	6
• <i>REPLACING THE FUSES</i>	6
• <i>SIDE BRUSH CONTROL</i>	7
• <i>ADJUSTING THE SIDE BRUSH</i>	7
• <i>REMOVING THE SIDE BRUSH</i>	7
• <i>RE-INSTALLING THE SIDE BRUSH</i>	7
• <i>THE MAIN BRUSH</i>	7
• <i>REPLACING THE MAIN BRUSH</i>	8
• <i>REPLACING THE RUBBER FLAPS (RIGHT AND REAR)</i>	8
• <i>REPLACING THE RUBBER FLAPS (LEFT SIDE)</i>	8
• <i>REPLACING THE FILTERS</i>	9
• <i>CHECKING THE HYDRAULIC OIL LEVEL</i>	9
• <i>REPLACING THE HYDRAULIC OIL FILTER</i>	9
• <i>CHARGING THE BATTERY</i>	9
• <i>TOWING THE MACHINE</i>	10
• <i>MOVING THE MACHINE WHEN ENGINE IS OFF</i>	10
• <i>EMERGENCY CASES</i>	10
• <i>WASTE MATERIAL</i>	10
• <i>VIBRATIONS</i>	11
• <i>NOISE LEVEL</i>	12-13
8. PLANNED MAINTENANCE CHART	14
9. TROUBLE-SHOOTING AND ALARMS GUIDE	15
10. THE OPTIONAL POLYESTER BAG FILTER	16
11. PRODUCT WARRANTY	
12. INSTALLATION FORM	

INTRODUCTION

“EUREKA S.r.l.” , leader manufacturer of sweeping machines, is pleased to welcome you as an owner of the “ MAGNUM EB” sweeper. We are sure that its use will give you great satisfaction and that while working with the MAGNUM EB you will have the opportunity to appreciate its quality, robustness, and versatility. The MAGNUM EB” is suitable for the cleaning of medium to large areas, for private, industrial and public use. In this handbook are described and shown various operations of installation, control and maintenance, necessary to keep your MAGNUM EB in perfect working condition. These are normal maintenance operations, which any operator can carry out with tools normally available. For additional maintenance operations you should contact your nearest EUREKA service point.

BEFORE USING THE MACHINE, CAREFULLY READ THIS MANUAL AND KEEP IT WITHIN EASY REACH FOR FURTHER CONSULTATION.

The observance of the instructions given in this manual, and a careful operator, are the best guarantee against accidents which may occur while working with the machine. The sweeping machines produced by EUREKA are designed according to the latest safety requirements, but they must be used following these instructions.

GENERAL NOTE

All information contained in this manual is current at the time of printing. However, due to constant updates and improvements, we reserve the right to make changes at any time without notice

WARNING AND RECOMMENDATIONS

IMPORTANT POINTS FOR THE SAFETY OF ALL THE PEOPLE INTERESTED IN THE USE OF THIS SWEEPER “MAGNUM EB”.

- THE SWEEPER HAS BEEN DESIGNED FOR THE CLEANING OF DRY FLOORS.
- DO NOT WORK IN THE PRESENCE OF TOXIC POWDERS.
- DO NOT WORK IN ENVIRONMENTS WHICH MAY BE UNDER RISK OF EXPLOSION.
- DO NOT COLLECT MATERIAL AND ALL THAT MAY LEAD TO FIRE (FOR EXAMPLE LIGHTED CIGARETTES)
- NEVER ALLOW ANYONE TO ENTER THE SWEEPER’S OPERATING AREA.
- NEVER LEAVE THE SWEEPER WITH THE ENGINE RUNNING ; TURN THE ENGINE OFF AND TAKE THE KEY AWAY.
- NEVER OPEN THE PROTECTIVE COVERS WHEN THE SWEEPER IS RUNNING.
- MAINTENANCE OPERATIONS SHOULD ONLY BE CARRIED OUT WITH THE ENGINE TURNED OFF.
- ONLY OPERATE THE SWEEPER FROM THE DRIVING SEAT.
- DO NOT ATTEMPT TO WORK ON SLOPES WHOSE GRADIENTS EXCEED THE VALUE SHOWN ON THE TABLE.
- DO NOT USE THE MACHINE FOR THE CLEANING OF OBJECTS.
- THE MAIN BRUSH MUST NOT SWEEP UP WIRES, ROPES, OR ANY OTHER LONG MATERIAL THAT MAY GET TANGLED WITH IT.
- DO NOT CARRY OUT ANY MODIFICATION TO THE MACHINE WITHOUT OUR PREVIOUS AUTHORISATION.
- THE SWEEPER IS NOT OMOLOGATED FOR USE ON PUBLIC STREETS.

N.B. EUREKA S.R.L. DECLINES ALL RESPONSIBILITIES FOR ANY DAMAGE TO PERSONS AND/OR PROPERTIES CAUSED BY FAILING TO OBSERVE THE ABOVE WARNINGS OR AS A CONSEQUENCE TO THE INAPPROPRIATE OR INCORRECT USE OF THE SWEEPER.

The sweeping machines manufactured by EUREKA follow the CE directory and show the label :



MAGNUM "EB" – MAJOR COMPONENTS

THE DASHBOARD

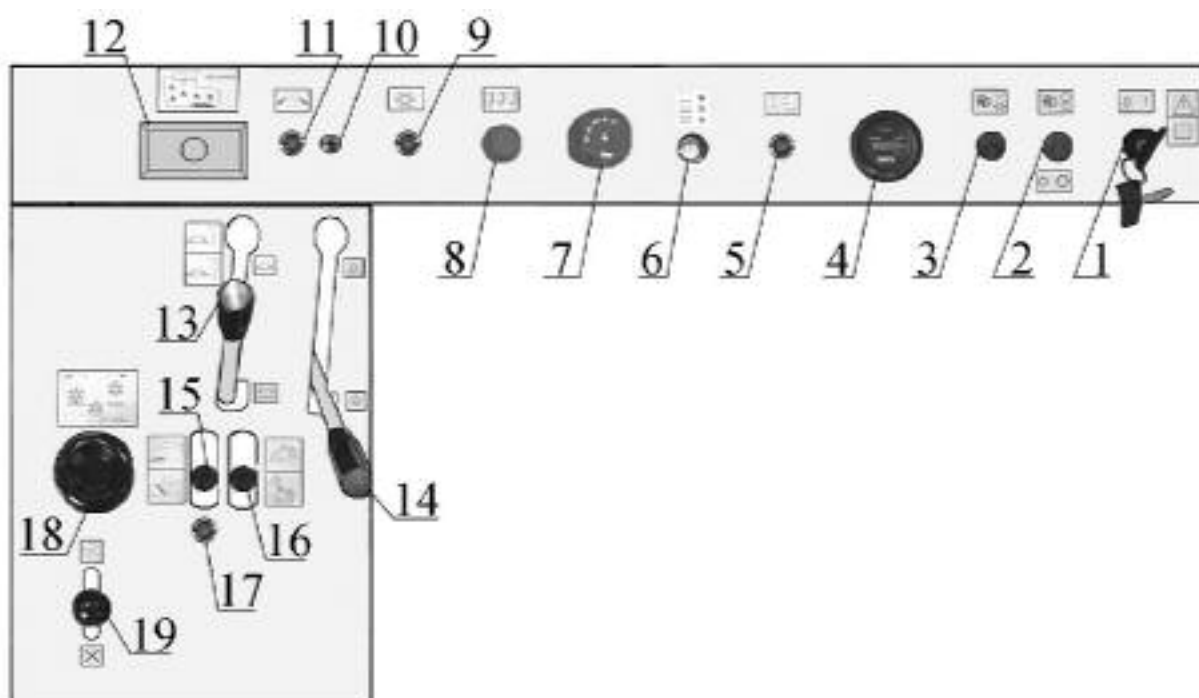



PIC. A

1. KEY SWITCH
2. PRIMARY MOTOR SWITCH
3. SECONDARY MOTOR SWITCH
4. HOUR METER
5. HYDRAULIC OIL TEMPERATURE WARNING LIGHT
6. BATTERY CHARGE INDICATOR
7. HEADLIGHTS & HORN SWITCH
8. FILTER-SHAKER BUTTON
9. MAIN BRUSH WARNING LIGHT
10. SIDE BRUSH MOTOR FUSE
11. SIDE BRUSH WARNING LIGHT
12. HOPPER FIRE DETECTOR WARNING LIGHT (OPTIONAL)
13. SIDE BRUSH LEVER
14. MAIN BRUSH LEVER
15. HOPPER DOOR CLOSE-OPEN LEVER
16. HOPPER UP-DOWN LEVER
17. CLOSED HOPPER DOOR WARNING LIGHT
18. MAIN BRUSH ADJUSTING KNOB
19. VACUUM CUT-OFF LEVER

BASIC OPERATING CONTROLS

- ⇒ **HOURLY METER:** Indicates the total running hours of the machine (n° 4 pic. A).
- ⇒ **HYDRAULIC OIL TEMPERATURE WARNING LIGHT:** If the temperature of the hydraulic oil in the tank exceeds 83° - 88°C the warning light will show. (n° 5 pic. A). **IMPORTANT!** You must stop the machine.
- ⇒ **BATTERY CHARGE INDICATOR:** It indicates the remaining level of charge of the battery (n°6 - pic.A). You may work while the green light is on. The yellow light indicates that you should re-charge the battery. When the red light shows, stop the machine immediately or the battery could get damaged irreversibly.
Besides the sweepers includes as standars an acoustic alarm (signal for low charge of battery). (See alarms - page 13)
- ⇒ **HEADLIGHTS & HORN SWITCH**
 - By turning the knob (n° 7 pic. A) clockwise, the headlights will switch-on.
 - To use the horn, press down the knob.
- ⇒ **FILTER-SHAKER FUNCTION:** The working efficiency of the Magnum is greatly influenced by the state of cleanliness of the filters; we therefore recommend to shake them frequently, especially if the area to be cleaned is particularly dusty.
TO SHAKE FILTERS:
 - Turn the key (n° 1 fig. A) to position 1.
 - Press the filter-shaker button (n° 8 fig. A) for 5÷10 seconds.
 - Repeat this operation a few times.
 - **NOTE:** Before shaking the filters, you must turn the secondary motor (n°3 pic.A) off.
- ⇒ **SAFETY FUSE FOR SIDE BRUSH MOTOR:** It stops the side brush to prevent damages to the motor.
RE-SET OPERATIONS:
 - After the brush stops, wait a few minutes, then:
 - Press the fuse rubber cap n° 10 fig. A.
 - The side brush should rotate.
 - **NOTE!** If the side brush stops again, please check if there is anything tangled in it. Then, clean it and repeat above operations.
- ⇒ **FIRE DETECTOR WARNING LIGHT (optional) :** It flashes (n° 12 fig. A) and activates an acoustic signal when temperature in the hopper exceeds 60°C.
 - **NOTE!** When this situation occurs, close immediately the vacuum (n° 19 Fig. A) and the rubbish box (n° 15 Fig. A). Then move the sweeper away from dangerous areas. Open the inspection door of the hopper and in case of fire extinguish it by mean of a **DRY FIRE EXTINGUISHER**
- ⇒ **DUMP DOOR WARNING LIGHT:** Warning light will show when the dump door is closed.(n°17 fig. A).
- ⇒ **MAIN BRUSH PRESSURE ADJUSTMENT KNOB:**
 - **TO INCREASE PRESSURE:** turn the knob (n° 18 pic. A) counter-clockwise.
 - **TO DECREASE PRESSURE:** turn the knob (n° 218 pic. A) clockwise.
- ⇒ **VACUUM CUT-OFF:** The vacuum-fan should be turned off (n°19 fig. A) when sweeping on wet areas, in order to protect the filters. It should be also turned off when shaking the filters.

DANGER AND OBLIGATION SYMBOLS

	DANGER SYMBOL. WARNING: very hot surfaces
	OBLIGATION SYMBOL. WARNING: Use adequate acoustic protection. In a number of working environments, sweepers might generate an acoustic danger which can be eliminated with adequate acoustic protection .

USE AND MAINTENANCE OF THE SWEEPER

Eureka sweepers should never be operated unless the operator is trained and authorised to operate the equipment and the sweepers are free of malfunctions. Malfunctioning equipment should be removed from service.

STARTING THE MACHINE	<ul style="list-style-type: none"> ⇒ Before starting the machine, make sure that main brush and side brushes are raised from the ground. ⇒ The operator must sit down on the machine's seat. NOTE! The seat is equipped with a micro-switch which cuts off all functions if the operator is not sat on it. ⇒ Turn the ignition key clockwise to position 1 (n°1 – pic.A) ⇒ Switch on the primary motor switch (n°2 – pic.A) <p style="text-align: center;">THE MACHINE IS READY TO MOVE</p>
STARTING THE FUNCTIONS	<ul style="list-style-type: none"> ⇒ The operator must sit down on the machine's seat. NOTE! The seat is equipped with a micro-switch which cuts off all functions if the operator is not sat on it. ⇒ Turn the ignition key clockwise to position 1 (n°1 – pic.A) ⇒ Switch on the secondary motor switch (n°3 – pic.A) <p style="text-align: center;">THE MACHINE IS READY TO WORK</p>
TURNING OFF THE MACHINE	<ul style="list-style-type: none"> ⇒ Disengage the switches n° 2-3 pic.A ⇒ Turn the ignition key counter-clockwise (n°1 – pic.A) to position 0

PIC. B

1. FWD\REV SPEED LEVER
2. PARKING BRAKE
3. EMERGENCY BRAKE
4. ACCELERATOR PEDAL
5. FUSES
6. HYDRAULIC DAMPER

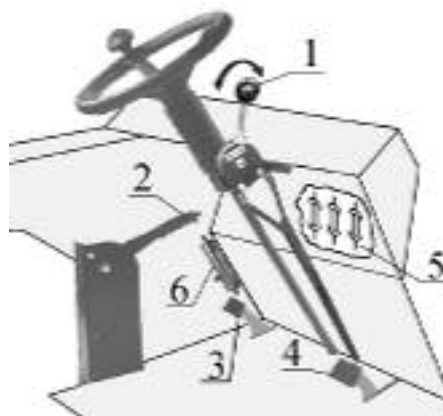

MOVING THE MACHINE	<ul style="list-style-type: none"> ⇒ FORWARD: pull-up the lever n°1 then press the accelerator pedal n° 4 ⇒ REVERSE: pull-down the lever n° 1 then press the accelerator pedal n° 4 <p style="text-align: center;">NOTE! Stop the machine before changing speed direction.</p>
PARKING BRAKE	<ul style="list-style-type: none"> ⇒ To engage it, push down the button then pull-up the lever n° 2
SERVICE BRAKE	<ul style="list-style-type: none"> ⇒ The service brake is engaged each time the accelerator pedal is released (n° 4)
EMERGENCY BRAKE	<ul style="list-style-type: none"> ⇒ To stop the machine in case of emergency, press the pedal n°3
REPLACING THE FUSES (N° 5)	<ul style="list-style-type: none"> ⇒ Remove the clamps from the battery (n°4 – pic.H). ⇒ Remove the metal protection. ⇒ Replace the fuse. ⇒ Re-assembly the unit. <p style="text-align: center;">NOTE! DON'T CHANGE THE AMPS. VALUE OF THE FUSE.</p>

PIC. C

1. SIDE BRUSH DRIVE SHAFT
2. SIDE BRUSH

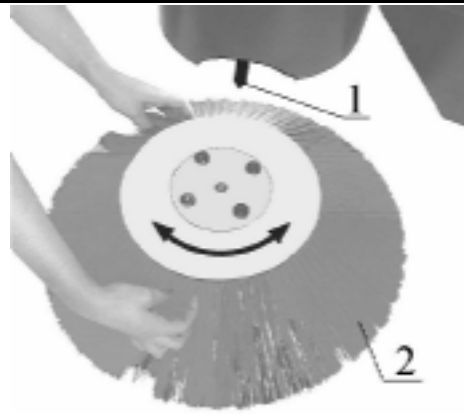
**SIDE BRUSH CONTROL**

- ⇒ The side brush can be raised or lowered by mean of the lever n°13 pic. A.
- NOTE!** The side brush will rotate when:
 1. The hopper is down and the lip is open;
 2. The main brush lever (n°14 pic. A) and side brush lever (n°13 pic. A), are lowered.

ADJUSTING THE SIDE BRUSH

- ⇒ INCREASE PRESSURE: turn the handle of lever (n°13 pic. A) counter-clockwise.
- ⇒ DECREASE PRESSURE: turn the handle of lever (n°13 pic. A) clockwise.

REMOVING THE SIDE BRUSH

- ⇒ Raise the brush (lever n°13 pic. A)
- ⇒ Hold the brush with both hands and turn it counter-clockwise (pic. C.)

RE-INSTALLING THE SIDE BRUSH

- ⇒ Match the side brush hub in the drive shaft (n° 1 pic. C)
- ⇒ Push it up and turn it slowly clockwise to match the seats.
- ⇒ Now turn it until completely connected.

PIC. D

1. MULTI-PURPOSE KEY
2. METAL RING
3. MAIN BRUSH
4. SUPPORT (RIGHT)

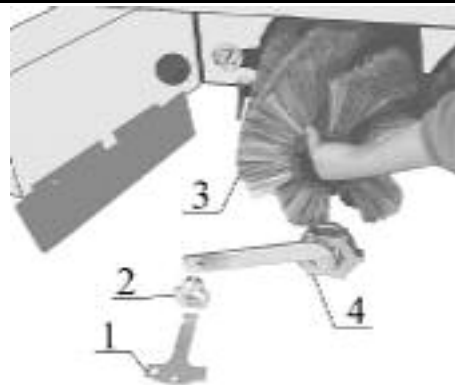
**MAIN BRUSH**

- ⇒ The main brush can be raised or lowered by mean of lever n° 14 pic. A.
- NOTE!** The main brush will rotate only when:
 1. The hopper is down and the lip is open;
 2. The main brush lever (n° 14 pic. A) is lowered.

REPLACING THE MAIN BRUSH

- ⇒ The motors must be turned off.
- ⇒ The hopper must be lowered: lever n°16 pic. A.
- ⇒ Hopper lip must be open: lever n°15 pic. A.
- ⇒ Main brush lever n°14 pic. A. must be lowered
- ⇒ Turn the starting key to position 1 (n°1 pic. A.)
- ⇒ Turn the adjustment knob completely (n°18 pic.A) clockwise, then counter-clockwise 3 turns.
- ⇒ Open the rear panel (n° 7 pic. G) and take the multi-purpose key (n°1 pic. G.)
- ⇒ Open the bottom metal right panel.
- ⇒ Remove the metal ring n°2 pic. D.
- ⇒ Remove the support n°4 pic. D, and the brush n° 3 pic. D.
- ⇒ Replace the brush, then re-assembly the unit making sure to set the brush lever and the starting key at their original position.
- ⇒ Adjust the clean path (max 50 – 60 mm) of the brush by turning the knob (n° 18 pic.A)

PIC. E

- 1. RIGHT SIDE RUBBER FLAP
- 2. REAR RUBBER FLAP

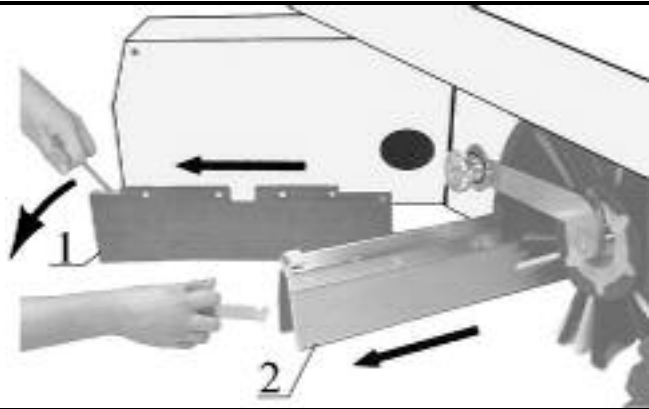

**REPLACING THE RUBBER FLAPS
(RIGHT AND REAR)**

- ⇒ Open the rear panel (n° 7 pic. G)
- ⇒ Take the multi-purpose key (n°1 pic. G.)
- ⇒ Open the bottom metal right panel
- ⇒ Hook the key to the flaps then pull as indicated in pic. E.
- ⇒ Replace the flaps.
- ⇒ Insert the new flaps in the correct brackets.

**REPLACING THE RUBBER FLAPS
(LEFT SIDE)**

- ⇒ Open the rear panel (n° 7 pic. G)
- ⇒ Take the multi-purpose key (n°1 pic. G.)
- ⇒ Open the bottom metal left panel
- ⇒ Remove the 2 metal locking rings.
- ⇒ Replace the flap, then re-assembly the unit.

PIC. F

- 1. PANEL FILTER
- 2. LOCK NUTS
- 3. SPRINGS
- 4. LOCK PLATE
- 5. LABEL
- 6. FILTER
- 7. FILTERS GASKET

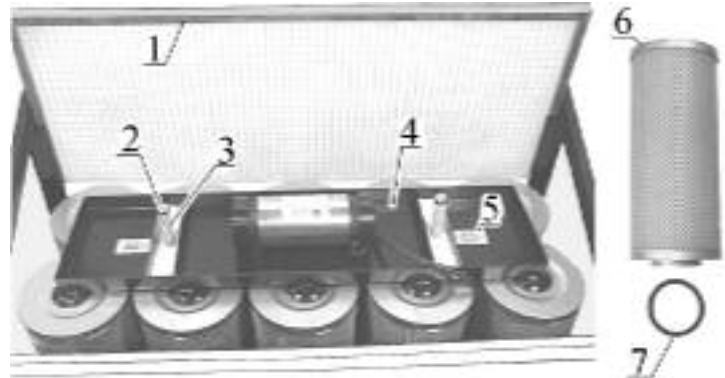

REPLACING THE FILTERS

- ⇒ Shake the filters throughout
- ⇒ Open the front hood
- ⇒ Remove the lock nuts (n° 2 pic. F) and the springs (n°3 pic. F).
- ⇒ Remove the lock plate (n° 4 pic. F).
- ⇒ Replace the filters (n° 6 pic. F).
- ⇒ Make sure both filters and gaskets (n°7 pic.F) are fitted properly in their seats.
- ⇒ Re-assembly the unit by locking the nuts, then press the springs as indicated on label (N° 5 PIC. F).

PIC. G

- 1. MULTI-PURPOSE KEY
- 2. AIR EXHAUST FILTER
- 3. PLUG - HYDRAULIC OIL TANK
- 4. HYDRAULIC OIL LEVEL GAUGE
- 5. HYDRAULIC OIL FILTER
- 6. RIGHT PANEL

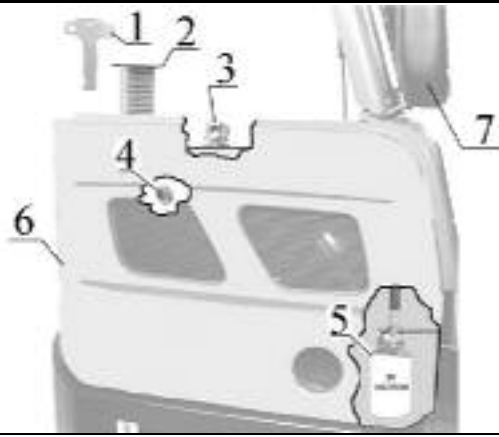

CHECKING THE HYDRAULIC OIL LEVEL

- ⇒ Check periodically (every 100 hours) the oil level (n°4 pic. G).
- ⇒ If level is low, add oil (plug n° 3 pic. G) up to the middle of indicator (n° 4 pic. G).
- ⇒ In case of leaks, consult a service centre.

REPLACING THE HYDRAULIC OIL FILTER

- ⇒ Remove the right panel n°6 pic. G.
- ⇒ Replace the filter (n°5 pic. G).

PIC. H

- 1. FUSE 80 A
- 2. FUSE 100 A
- 3. LEFT SIDE PANEL
- 4. BATTERY CONNECTOR
- 5. BATTERY
- 6. ELECTRONIC CARD

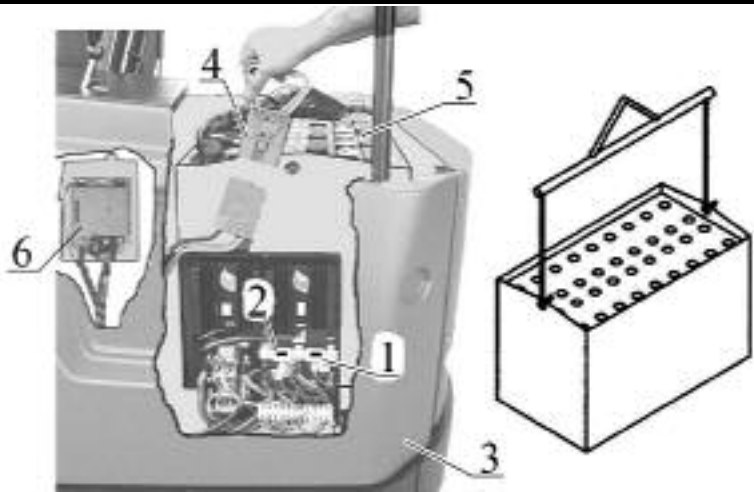

CHARGING THE BATTERY

- ⇒ Turn off the sweeper
- ⇒ Open the rear hood (n°7 – pic.G)
- ⇒ Disconnect the connector n°4 and connect the battery charger connector
- ⇒ Read the battery charger instruction manual for a correct use of the charger
- ⇒ The rate of charge should not exceed 1/20 of the battery capacity
- ⇒ After charging the battery, check the acid level and top up if necessary
- ⇒ Connect the mobile connector n°4 into the fixed connector
- NOTE:**
- ⇒ Batteries must be charged in ventilated places.
- ⇒ The gas generated during charging operations may produce explosions when in presence of flames or sparks.
- ⇒ The battery acid must not come in contact with eyes, skin, clothes, painted or zinc coated surfaces.
- ⇒ Should this happen, wash off the acid with water.
- ⇒ Do not lean metallic objects over the batteries.
- ⇒ Remove all caps from the various battery cells before charging the battery.
- ⇒ Do not top up with sulphuric acid.

PIC. I

TOWING THE MACHINE

- ⇒ Remove the foot panel n° 1.
- ⇒ Release the bolt n° 2.
- ⇒ Remove the chain joint n° 3.
- ⇒ Remove the chain n° 4 .
- ⇒ Re-assemble the foot panel n°1.
- ⇒ Tow the machine without exceeding speed of 3 – 4 Km/h.

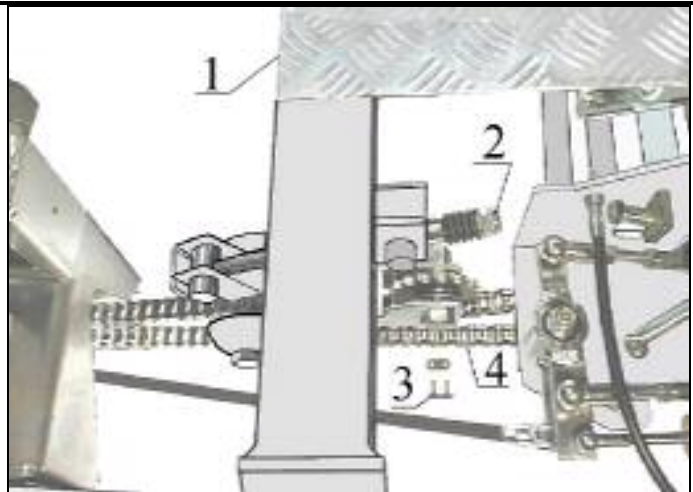

MOVING THE MACHINE WHEN ENGINE IS OFF ⇒ Push the sweeper only for a short distance (about 3 m), or until it stops. Wait 1 min then repeat

EMERGENCY CASES

Strictly observe the following instructions :

- ⇒ In the event of fire, use only powder fire extinguishers.
- ⇒ In the event of unusual failures (engines or motor overheating, etc.) turn off immediately the machine

WASTE MATERIAL.

For the dumping of waste material such as oil, plastic part, batteries, packing boxes, please contact those facilities authorised for the dumping of special waste.

VIBRATIONS

The level of vibration to which the operator is subjected is below the maximum level allowed by the CE DIRECTORY for industrial machinery (CEE 89\392).

NOISE LEVEL

The level of noise has been measured to the level of the operator's ear and while the machine is working .
⇒ The maximum value read is XXXXX dB.

PLANNED MAINTENANCE CHART

INTRODUCTION

Regular maintenance on your sweeper results in better cleaning, faster cleaning, and a prolonged service life for the equipment and components. This section contains the following information to help you give your sweeper the maintenance attention it requires.

WARNING: never attempt to perform any service on the equipment or components until the machine is OFF, the parking brake is LOCKED, the wheels are CHOCKED, the battery clamps are DISCONNECTED

WARNING: The safety parts and devices must not be tampered with. They can be removed only when executing maintenance operations and by Authorised Service Centres (ASC).

FREQUENCY (IN HOURS)								SERVICE
DAILY	50	100	200	300	500	1000	2000	
	X				X X			<ul style="list-style-type: none"> • <u>ELECTRICAL SYSTEM</u> ⇒ Check electrolyte level in starting battery and fill as needed ⇒ Check state of wear of electric motor carbon brushes ⇒ Clean air intakes of electric motors
		X						<ul style="list-style-type: none"> • <u>HYDRAULIC SYSTEM</u> ⇒ Check hydraulic fluid level and fill as needed ⇒ REPLACE hydraulic fluid ⇒ REPLACE filter (1st time) ⇒ REPLACE filter
							ACS	
		ACS			ACS			
X								<ul style="list-style-type: none"> • <u>SWEEPING COMPONENTS</u> ⇒ Inspect main and side brooms for wear and remove strings\debris from bristles and drive assembly ⇒ Perform main broom adjustment test and adjust as needed ⇒ Inspect main broom door seals\flaps for wear ⇒ REPLACE flaps as needed ⇒ ACS to REPLACE seals as needed ⇒ REPLACE main and side brooms as needed
X	X							
	X							<ul style="list-style-type: none"> • <u>FILTERS</u> ⇒ Check and clean cartridge filters ⇒ REPLACE cartridge filters as needed ⇒ Check and clean main panel filter ⇒ Check and clean panel filter on air exhaust ⇒ REPLACE main panel filter as needed ⇒ REPLACE panel filter on air exhaust as needed
X	X							
X X								<ul style="list-style-type: none"> • <u>HOPPER</u> ⇒ Check hopper flaps for wear or damage and replace as needed ⇒ Check hopper door rubber seals for wear or damage and replace as needed
			ACS ACS ACS ACS					<ul style="list-style-type: none"> • <u>LUBRICATED COMPONENTS</u> ⇒ Check and if needed lubricate <i>steering shaft</i> and <i>links</i> ⇒ Check and if needed lubricate <i>gearbox</i> unit ⇒ Check and if needed lubricate <i>main brush floating shaft</i> ⇒ Lubricate the transmission chain by the appropriate lubricating
	X X		ACS ACS					<ul style="list-style-type: none"> • <u>MISCELLANEOUS</u> ⇒ Check belts tension and adjust as needed ⇒ Check chains tension and adjust as needed
						ACS ACS		<ul style="list-style-type: none"> ⇒ REPLACE belts ⇒ REPLACE chains
			ACS					<ul style="list-style-type: none"> ⇒ Check inlet\outlet vacuum hoses
			ACS	ACS				<ul style="list-style-type: none"> ⇒ REPLACE inlet\outlet vacuum hoses ⇒ Check all brakes for proper functioning and adjust as needed

TROUBLE-SHOOTING GUIDE

WARNING! Any other type of service operation or test, with the exception of those shown in the engine's manual or the battery's manual, must be carried out by Authorised Service Centres only.

PROBLEM	CAUSE	SOLUTION
The machine will not start	1. Flat or worn out battery 2. Fuse is blown	1. Re-charge or replace the battery 2. Replace it
The battery does not maintain the charge	3. Motors are over loaded 4. The density of the electrolyte solution is low	3. Remove any object that could cause friction 4. Check the battery
The primary motor is on, but the sweeper does not move.	5. Chain is broken 6. Belts are broken 7. Hydrostatic drive is broken	5. Replace it 6. Replace belts 7. Replace it
The motor switch is on but the motor will not start	8. Fuse is blown 9. Solenoid is broken 10. Electronic card is faulty 11. Micro-switch is faulty 12. Motor is faulty	8. Replace it 9. Replace it 10. Check it\replace it 11. Repair\replace it 12. Repair\replace it
The secondary motor will not start	13. Fuse is blown 14. Solenoid is broken 15. Micro-switch is faulty 16. Motor is faulty	13. Replace it 14. Replace it 15. Repair\replace it 16. Repair\replace it
Dust in the bonnet	17. Broken or old filters. 18. Filter gaskets have not been mounted	17. Replace the filters 18. Mount the gaskets
Uneven sweeping action by main brush	19. Worn main brush 20. Brush is raised from floor 21. Some material may be tangled with brush 22. Low brush pressure to floor	19. Replace the brush . 20. Lower it 21. Clean main brush 22. Increase pressure
Dust and debris leak out from container	23. Rubber flaps are worn or broken	23. Replace them
No vacuum power	24. Vacuum fan is off 25. Filters are clogged 26. Fan belt is broken 27. Side panels in main brush compartment are open	24. Turn it on 25. Clean or replace filters 26. Replace belt 27. Close them
Filter shaker does not work	28. Blown fuse 29. Faulty filtershaker 30. Faulty filter-shaker button	28. Replace it 29. Check and repair\replace it 30. Check and repair\replace it
Main brush does not work	31. Belt is broken 32. Belt is loose 33. Electro-magnetic clutch is off 34. Electro-magnetic clutch is broken 35. Microswitches: Main brush m.s.; Hopper door m.s.; Hopper lift m.s.: any of above features are off or broken	31. Replace it 32. Check belt tensioner or replace it 33. Turn it on 34. Replace it 35. Turn it on or replace it
Side brush does not work	36. Belt is broken 37. Reduction motor is burnt or faulty 38. Safety fuse is still engaged 39. Main brush is off 40. Microswitch is faulty	36. Replace it 37. Check and repair\replace it 38. Disengage it 39. Turn it on 40. Check and repair\replace it

PROBLEM	CAUSE	SOLUTION
Hopper will not raise	41. Hopper load is too heavy 42. Pump is faulty 43. Hydraulic distributor is faulty 44. Lift cylinder is faulty 45. Hydraulic flow limit valve is faulty	41. Dump more frequently 42. Check and repair\replace pump 43. Check and repair\replace it 44. Replace the seals 45. Check and repair\replace it
Hopper can not be lowered	46. Safety bar is installed on lift cylinder 47. Hydraulic distributor is faulty 48. Hydraulic flow limit valve is faulty 49. Lift cylinder is blocked	46. Remove it 47. Check and repair\replace it 48. Check and repair\replace it 49. Check and repair\replace it
Hopper door will not close	50. Hopper is over-filled 51. Piston is blocked 52. Hydraulic distributor is faulty 53. Check and repair\replace it	50. Dump more frequently 51. Check and repair\replace it 52. Replace it 53. Check and repair\replace it
Hopper door will not open	54. Debris may obstacle the door 55. Piston is blocked 56. Hydraulic distributor is faulty 57. Check and repair\replace it	54. Remove all debris 55. Check and repair\replace it 56. Check and repair\replace it 57. Check and repair\replace it

ALARMS

The sweeper includes nr. 2 acoustic alarms as standard accessories:

- 1) Acoustic intermittance alarm indicating low charge of battery
It starts when the charge level of battery is inferior to the one stated. You have to stop and charge the battery in order to avoid irreversible damage to it.
- 2) Continuous acoustic alarm indicating high temperature or short circuit
It is mounted in the starting chopper (electric card) of the main engine.
It starts, on stopping the engine, when the temperature of the chopper goes over 90 °, or when there is a short circuit.

Pay attention that the above mentioned alarms starts for about 3-4 seconds when you insert the key on the dashboard (page 4 – pos. 1).

In this way the correct function of the alarm cards are tested.

THE OPTIONAL POLYESTER BAG FILTER

The **optional** polyester bag filter is particularly recommended in presence of very fine dust and applications such as cement plants, chalk plants, talcum powder plants and other similar products.

To achieve best performances, shake the filter often (every 15 – 20 minutes) or at least prior to dump the dirt.

NOTE: the dirt container must be lowered to the floor when shaking the filter.

Every 100 hours, shake the filter throughout and clean it with compressed air **without** removing it from its support.



TECHNICAL SPECIFICATIONS

COMPOSITION	POLYESTER FIBRE
WEIGHT (g/m²)	400
THICKNESS	mm 1,25
DENSITY (g/cm³)	0,32
AIR PERMEABILITY	DIN 53887 lt/dm ² x min. 180
FILTERING AREA (m²)	6
FILTERING CLASS	S Max penetration value = 1% Dusts with values of max. occupational exposure > 0,1 mg/m ³

EXPLODED VIEW

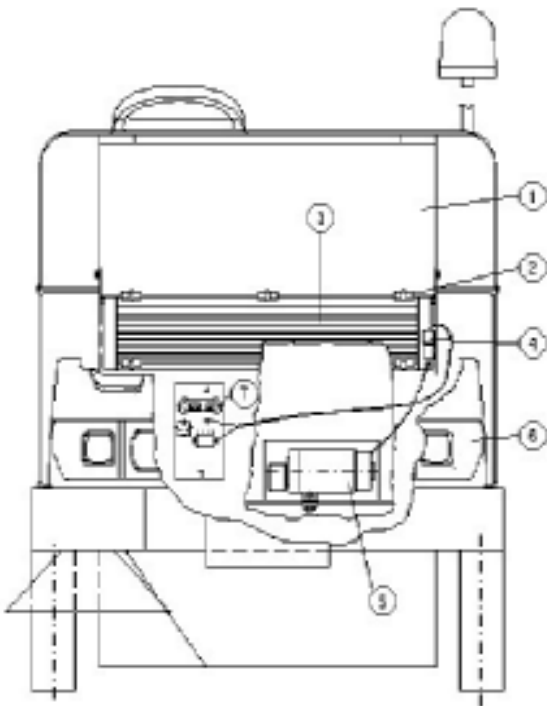

1. FILTER COMPARTMENT HOOD
2. LOCKING BOLTS
3. POLYESTER FILTER
4. CONNECTOR
5. 12V FILTER-SHAKER (36V ON "EB" VERSION)
6. FRONT ABS PANEL
7. 40 Amps. FUSE (30 A. ON "EB" VERSION)

REMOVING THE FILTER:

- A. REMOVE THE HOOD n° 1
- B. REMOVE THE BOLTS n° 2
- C. REMOVE THE POLYESTER FILTER n° 3
- D. DISCONNECT THE CONNECTOR n° 4

REPLACING THE FUSE

- E. OPEN THE FILTER COVER n°1
- F. REMOVE THE FRONT ABS PANEL n° 6
- G. REPLACE THE FUSE n° 7

NOTE: DO NOT CHANGE THE Amps. VALUE OF THE FUSE



MAGNUM EB (LIMITED) PRODUCT WARRANTY

Eureka srl warrants that the MAGNUM EB will be free from defects in material and workmanship for a period of 12 months from date of installation. Written notice of any claimed defect must be given to Eureka srl or its Authorised Sales/Service Representative within the warranty period and within thirty (30) days after such defect is discovered. Liability under this warranty is limited to either replacing or repairing, at Eureka or its Authorised Sales/Service Representative election, any part or parts deemed defective after examination.

This warranty does not extend to labor charges, handling charges or transport charges.

This warranty does not extend to the MAGNUM EB, or its parts, that have been subject to misuse, accident or improper handling, installation, maintenance or application, nor does it extend to the MAGNUM EB and/or parts which have been repaired or altered outside Eureka's plant or the facility of Eureka's Authorised Sales/Service Representative.

This warranty does not apply to routine wearable parts of the MAGNUM EB such as brushes, flaps, filters, seals, plugs, hoses, fuses or similar items. Moreover, this warranty does not extend to the MAGNUM EB or any of its parts already repaired or replaced under this warranty.

Only replacement parts supplied by Eureka or Eureka's Authorised Sales/Service Representative are warranted for 30 days after installation.

The warranty for engines shall be limited to the warranty extended by the engine's manufacturer.

IMPORTANT!

Warranty claims will be evaluated only if the following Installation Form will be sent by fax or by mail, filled in all its parts, to Eureka's headquarter within thirty (30) days after the machine's installation.

EUREKA S.r.l.

Via dell'Industria 32, 35013 CITTADELLA (PD) ITALY

Tel. ++39 - 049- 9481800

Fax. ++39 -049 - 9481899

INTERNET: www.eurekasweepers.com E-MAIL: info@eurekasweepers.com

INSTALLATION FORM – MAGNUM EB

Warranty claims will be evaluated only if a copy of the following Installation Form will be sent by fax or by mail, filled in all its parts, to Eureka's headquarter within thirty (30) days after the machine's installation. Please retain the original copy within the manual.

USER'S INFORMATION	
COMPANY NAME	
ADDRESS	
TEL	
FAX	
INTERNET ADDRESS	
E-MAIL	
BUSINESS ACTIVITY	

APPLICATION INFORMATION	
TYPE OF AREA TO CLEAN	
APPROX. SIZE OF AREA (sq.mt)	

MACHINE INFORMATION	
SERIAL NUMBER	
MACHINE SOLD BY	
MACHINE INSTALLED ON DATE	

GENERAL INFORMATION	
1. THE DATE OF DELIVERY HAS BEEN RESPECTED ?	
2. HAVE YOU BEEN SHOWN HOW TO USE THE MACHINE?	
3. HAVE YOU CHECKED THE PERFECT FUNCTIONING OF THE MACHINE PRIOR TO ITS FIRST USE?	
4. DID YOU READ THE OPERATION MANUAL PRIOR TO USE THE MACHINE?	
5. HAVE YOU BEEN OFFERED A PREVENTIVE "MAINTENANCE CONTRACT" ?	
6. DID YOU ACCEPT IT?	

DATE	
SIGNED BY:	
POSITION:	

Eureka srl
Via dell'Industria 32,
35013 CITTADELLA (PD)
Italy
Tel ++39 - 049 - 9481800
Fax ++39 - 049 - 9481899