

# FSR7 FSR8



PROFESSIONAL SCRUBBING MACHINES

## *OPERATOR INTERFACE CONFIGURATION MANUAL*

 **FIMAP**<sup>®</sup>



A TRANSLATION OF THE ORIGINAL INSTRUCTIONS DOC. 10126398 - Ver. AB - 01-2025

The constructive elements and content of this manual, including the structure, text, diagrams, images and logo, are the exclusive property of FIMAP S.P.A.. They are protected, both collectively and individually, by the current regulations regarding intellectual property (including copyright laws), and cannot be either wholly or partially copied or imitated. Any reproduction, reprocessing, distribution or dissemination is strictly prohibited.



# CONTENTS

CONTENTS.....	3
SETTING MENU NAVIGATION DIAGRAM.....	5
SETTINGS MENU.....	12
GENERAL SETTINGS MENU (SETTINGS).....	14
MAIN MENU (GENERAL SETS).....	14
LANGUAGE SELECTION MENU (GENERAL MAIN).....	15
DISPLAY TUNE MENU (GENERAL MAIN).....	15
DISPLAY BRIGHTNESS MENU (GENERAL MAIN).....	16
BATTERY MENU (GENERAL SETS).....	16
BATTERY TYPE MENU (GENERAL BATTERY).....	16
CUSTOM LEVEL MENU (GENERAL BATTERY).....	17
HOUR METER MENU (GENERAL SETS).....	17
PARTIAL HMR O DISPLAY MENU (GENERAL HOUR METER).....	18
PARTIAL HMR RESET MENU (GENERAL HOUR METER).....	18
ACCESS MODE MENU (GENERAL SETS).....	19
PASSWORD 3 CUSTOM MENU (GENERAL ACCESS MODE).....	19
PASSWORD 4 USER MENU (GENERAL ACCESS MODE).....	20
PASSWORD 5 PIN MENU (GENERAL ACCESS MODE).....	20
PROT USER PASSWORD MENU (GENERAL ACCESS MODE).....	21
PROT PIN PASSWORD MENU (GENERAL ACCESS MODE).....	21
CONFIG MENU (GENERAL SETS).....	22
WORKLIGHT ENABLING MENU (GENERAL CONFIG).....	22
ANTI-COLLISION MENU (GENERAL CONFIG).....	23
HAZARD LIGHTS MENU (GENERAL CONFIG).....	23
MANUAL OP ENABLING MENU (GENERAL CONFIG).....	24
ZONE OP ENABLING MENU (GENERAL CONFIG).....	24
BRUSH SETTINGS MENU (SETTINGS).....	25
BRUSHMOTOR MENU (BRUSH SETTINGS).....	25
DELAY RESET MENU (BRUSHES BRUSHMOTOR).....	26
SPEED REDUCTION MENU (BRUSHES BRUSHMOTOR).....	26
PRESSURE LEVEL MENU (BRUSHES BRUSHMOTOR).....	27
PRESSURE RANGE MENU (BRUSHES BRUSHMOTOR).....	27
VACUUM SETTINGS MENU (SETTINGS).....	28
VAC. MOTOR MENU (VACUUM SETTINGS).....	28
VACUUM NOISE LEVEL MENU (VACUUM MOTOR).....	29
SHAKE MOTOR MENU (VACUUM SETTINGS).....	29
SHAKE MOTOR FREQUENCY MENU (VACUUM SHAKE MOTOR).....	30
OPTIONAL SETTINGS MENU (SETTINGS).....	30
BRUSH FUNCTION MENU (OPTIONAL SETTINGS).....	31
DELAY RESET MENU (OPTIONAL BRUSH FUNCTION).....	31
TRACTION SETTINGS MENU (SETTINGS).....	32
SPEED SETS MENU (TRACTION SETS).....	32
ACCELERATION RAMP #1 MENU (TRACTION SPEED SETTINGS).....	33
ACCELERATION RAMP #2 MENU (TRACTION SPEED SETTINGS).....	34
DECCELERATION RAMP #1 MENU (TRACTION SPEED SETTINGS).....	34
DECCELERATION RAMP #2 MENU (TRACTION SPEED SETTINGS).....	35
DECCELERATION RAMP STOP MENU (TRACTION SPEED SETTINGS).....	35
REVERSE RAMP #1 MENU (TRACTION SPEED SETTINGS).....	36

REVERSE RAMP #2 MENU (TRACTION SPEED SETTINGS).....	36
MAX FORWARD SPEED MENU (TRACTION SPEED SETTINGS).....	37
MAX BACKWARD SPEED MENU (TRACTION SPEED SETTINGS).....	37
MINIMUM SPEED MENU (TRACTION SPEED SETTINGS).....	38
MODE1 SPEED MENU (TRACTION SPEED SETS).....	38
MODE1 CURRENT MENU (TRACTION SPEED SETTINGS).....	39
MODE2 SPEED MENU (TRACTION SPEED SETS).....	39
SPEED LEVEL MENU (TRACTION SPEED SETS).....	40
SPEED REF MENU (TRACTION SETTINGS).....	40
MIN POSITION SIGNAL MENU (TRACTION SPEED REF).....	41
MAX POSITION SIGNAL MENU (TRACTION SPEED REF).....	41
DEAD BAND SIGNAL MENU (TRACTION SPEED REF).....	42
MID SIGNAL MENU (TRACTION SPEED REF).....	42
MOTOR SETTINGS MENU (TRACTION SETTINGS).....	43
CURRENT BOOST MENU (TRACTION MOTOR SETTINGS).....	43
BOOST TIME MENU (TRACTION MOTOR SETTINGS).....	44
MONITOR MODE MENU (SETTINGS).....	44
MONITOR SETTINGS MENU (MONITOR MODE).....	45

# SETTING MENU NAVIGATION DIAGRAM

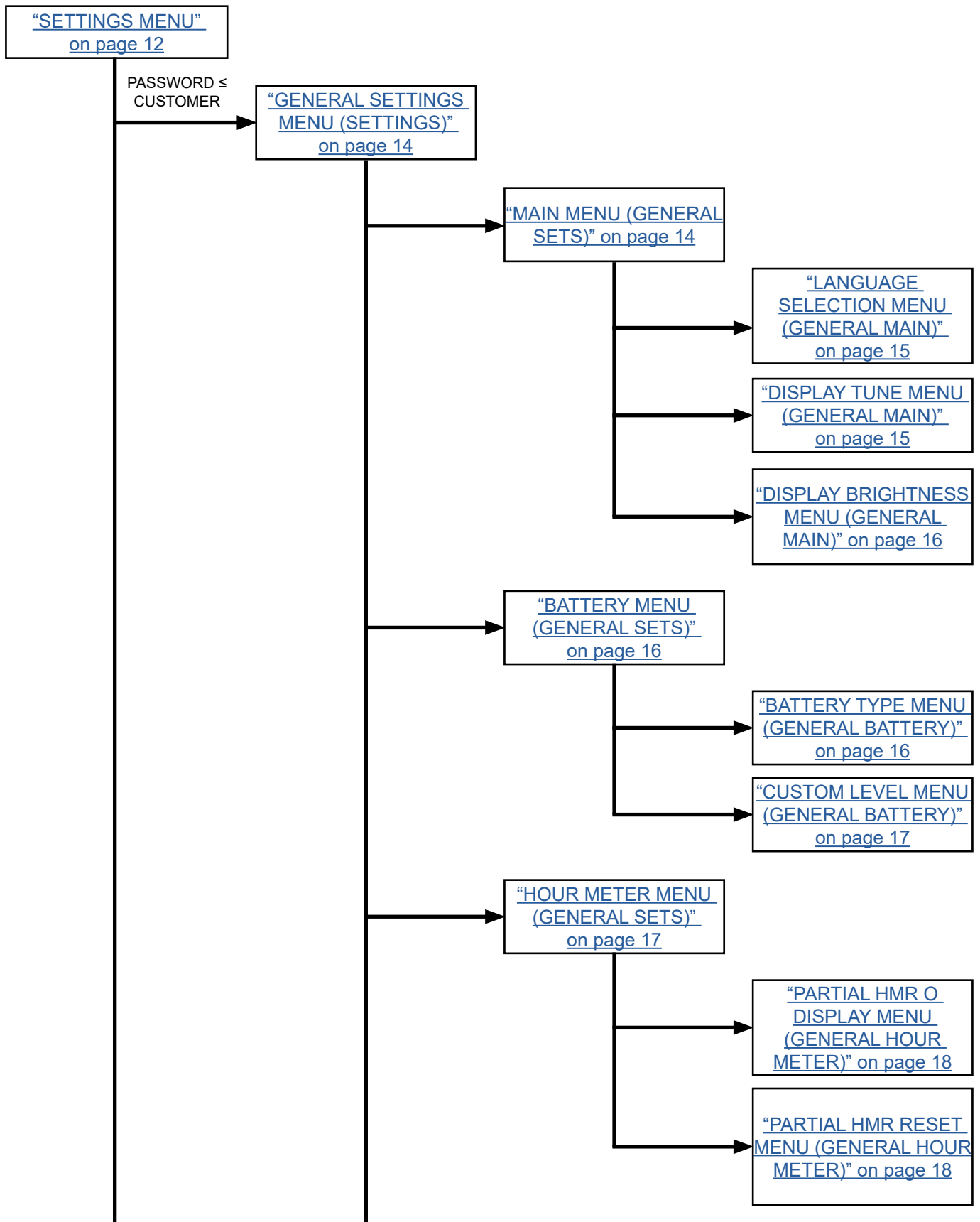

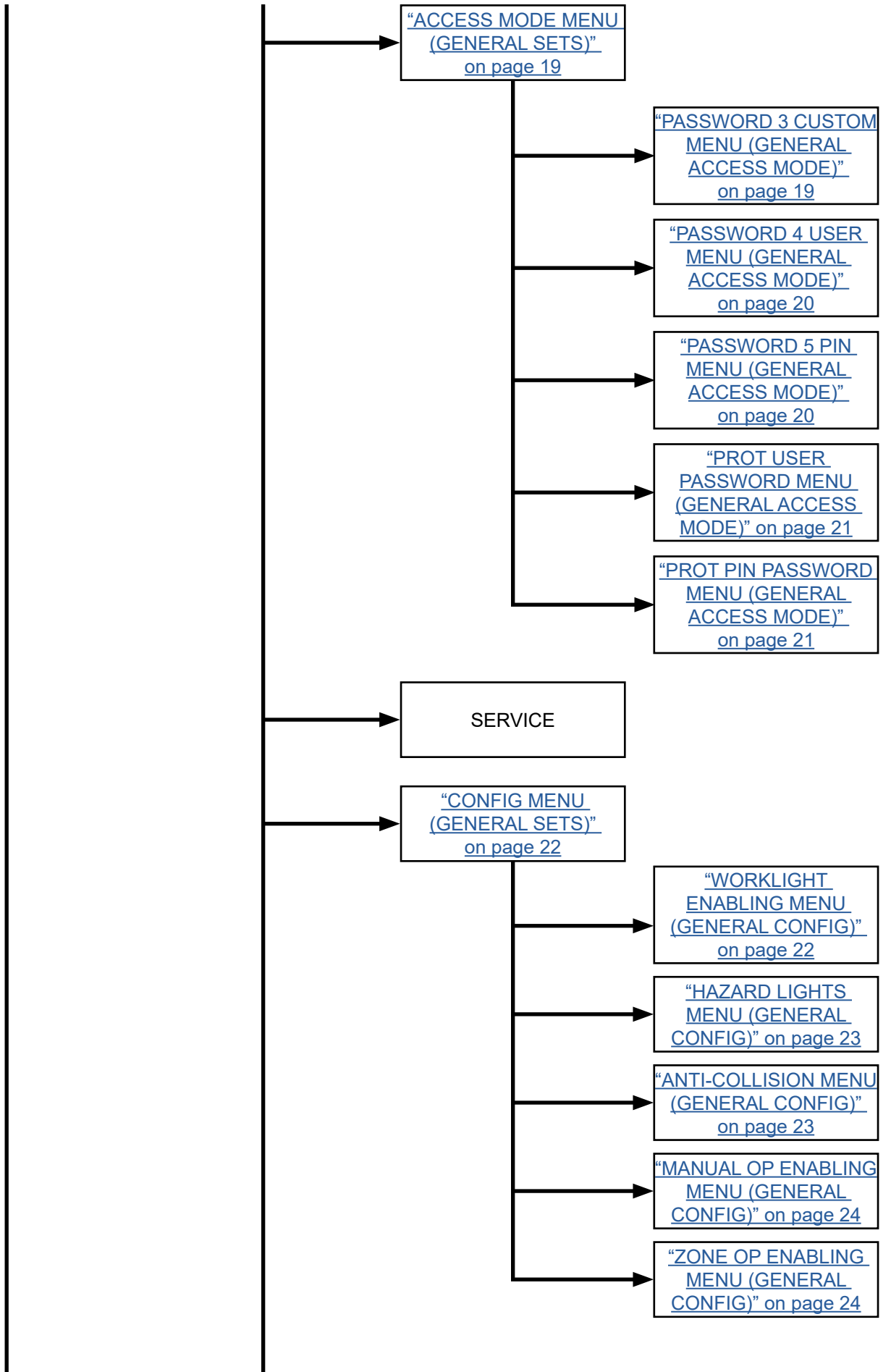

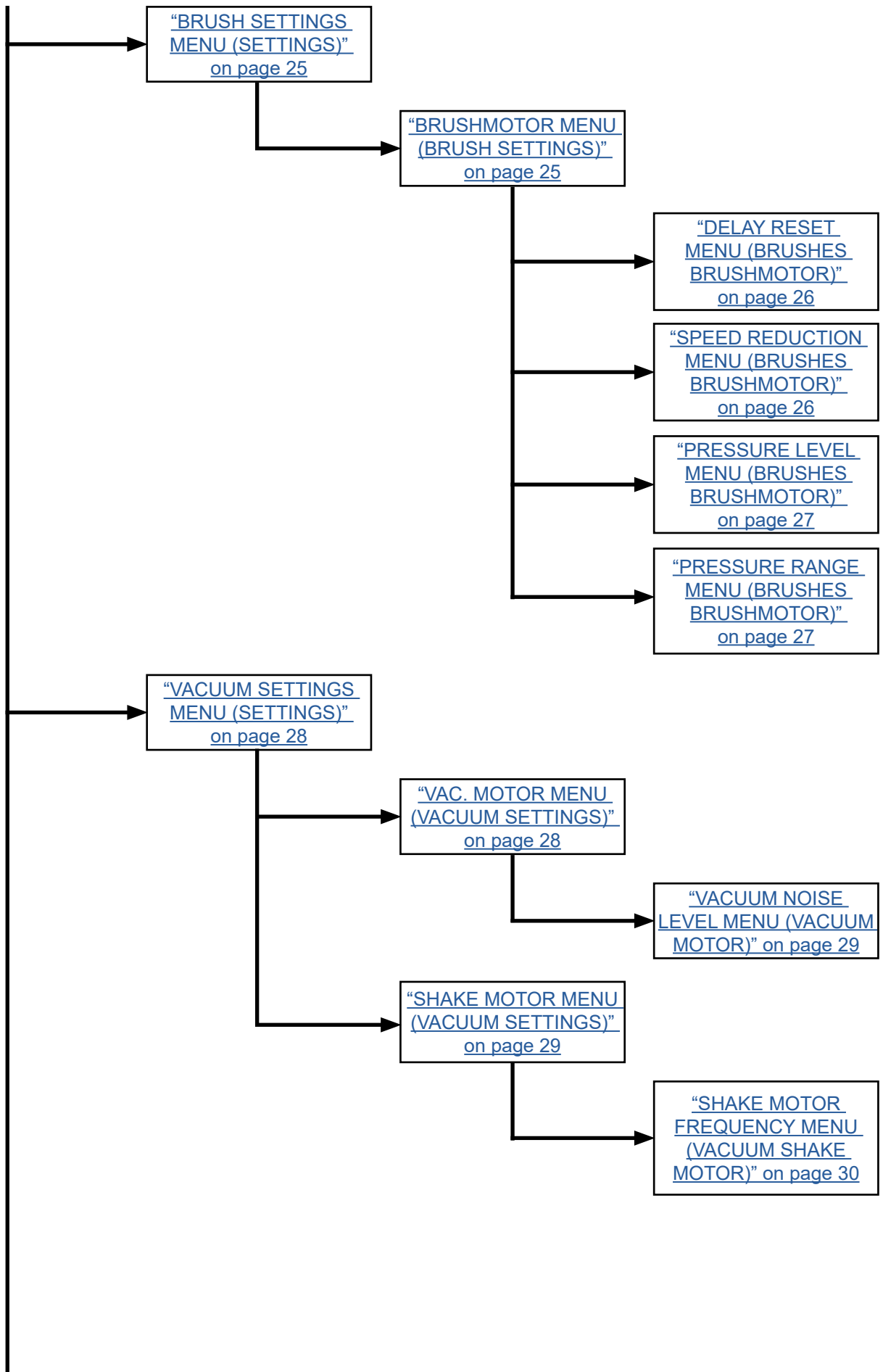

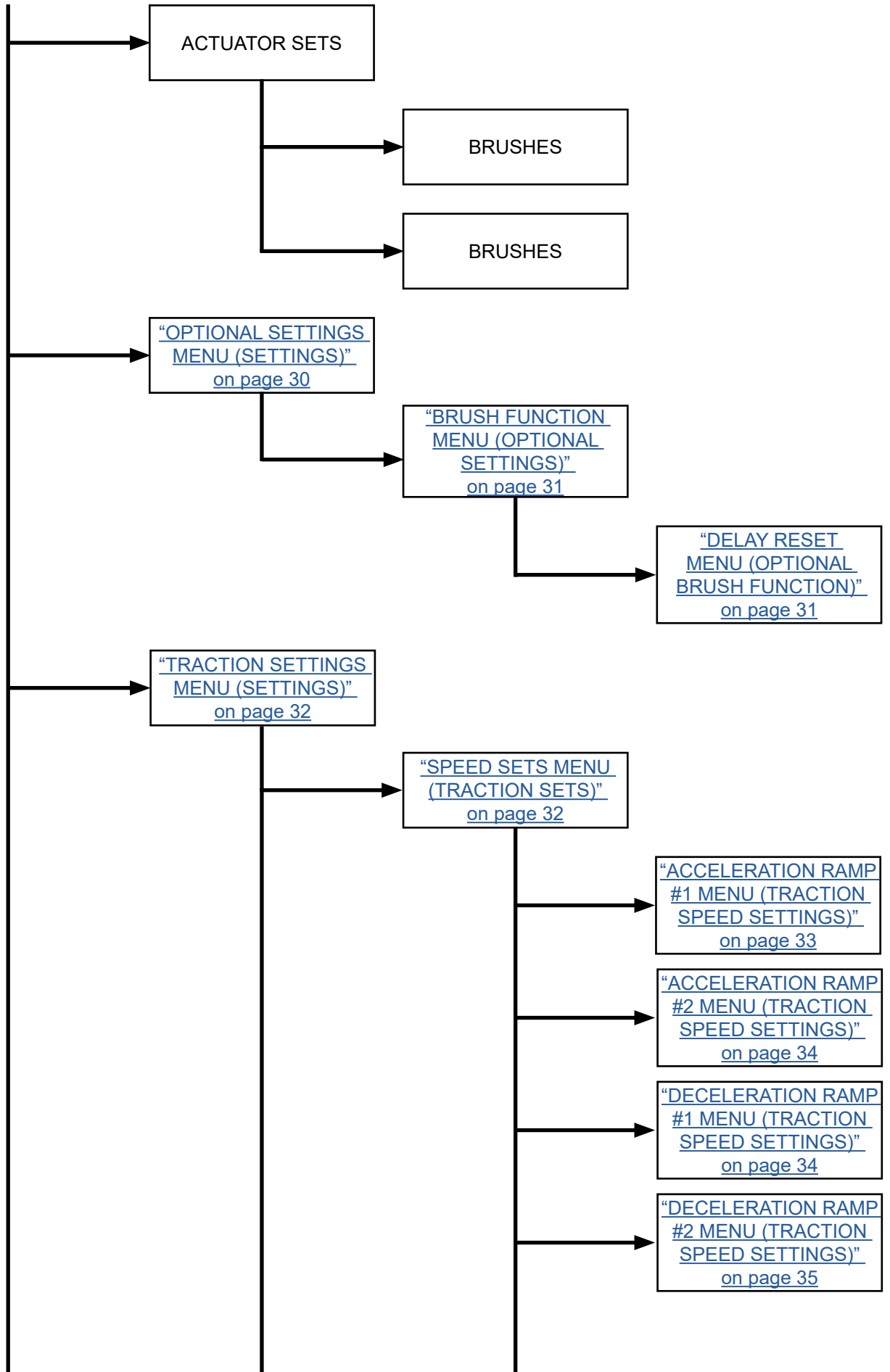

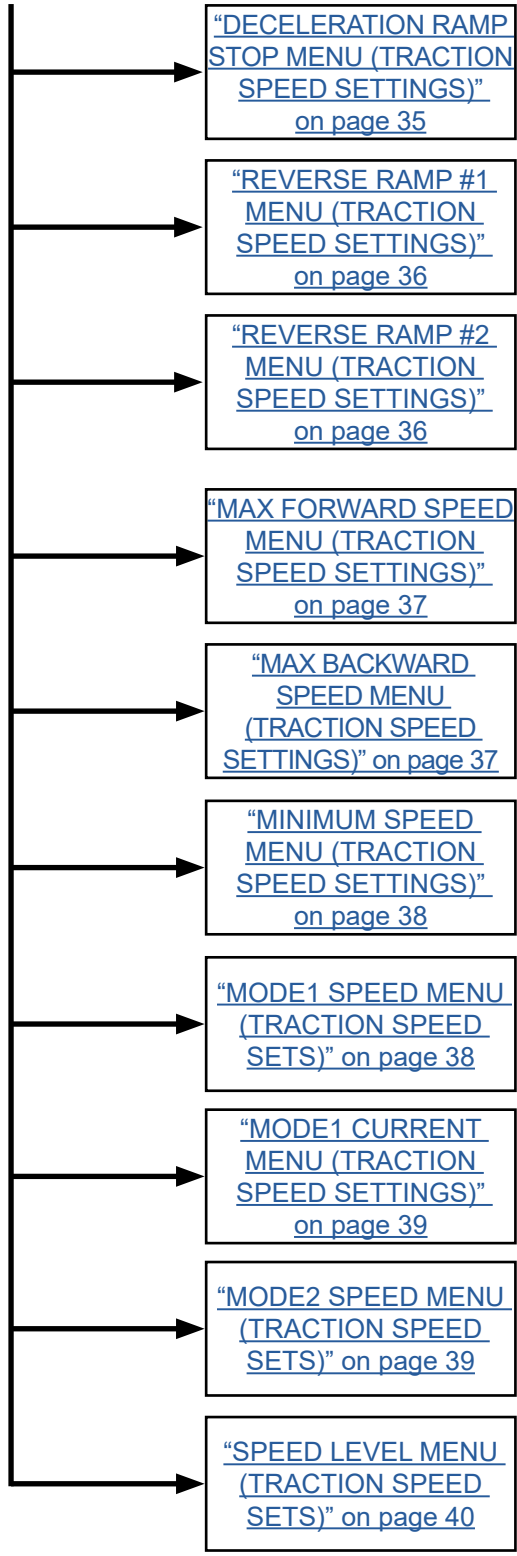
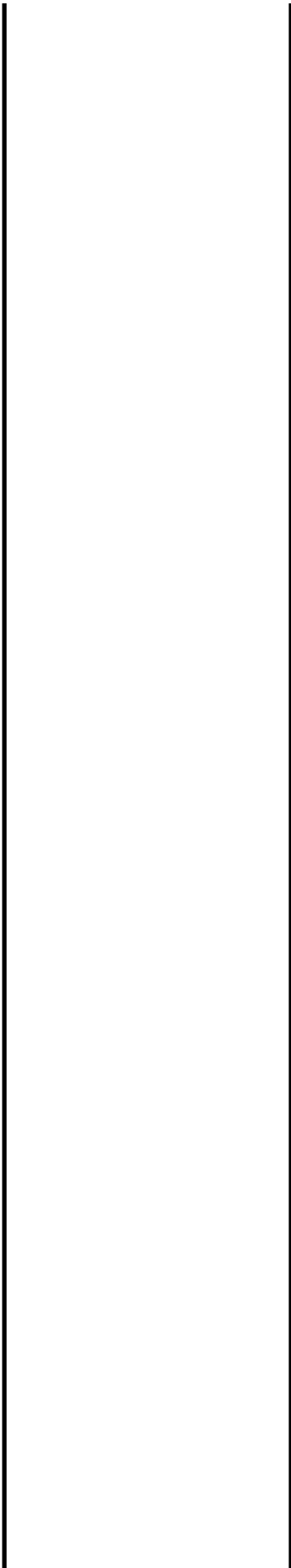

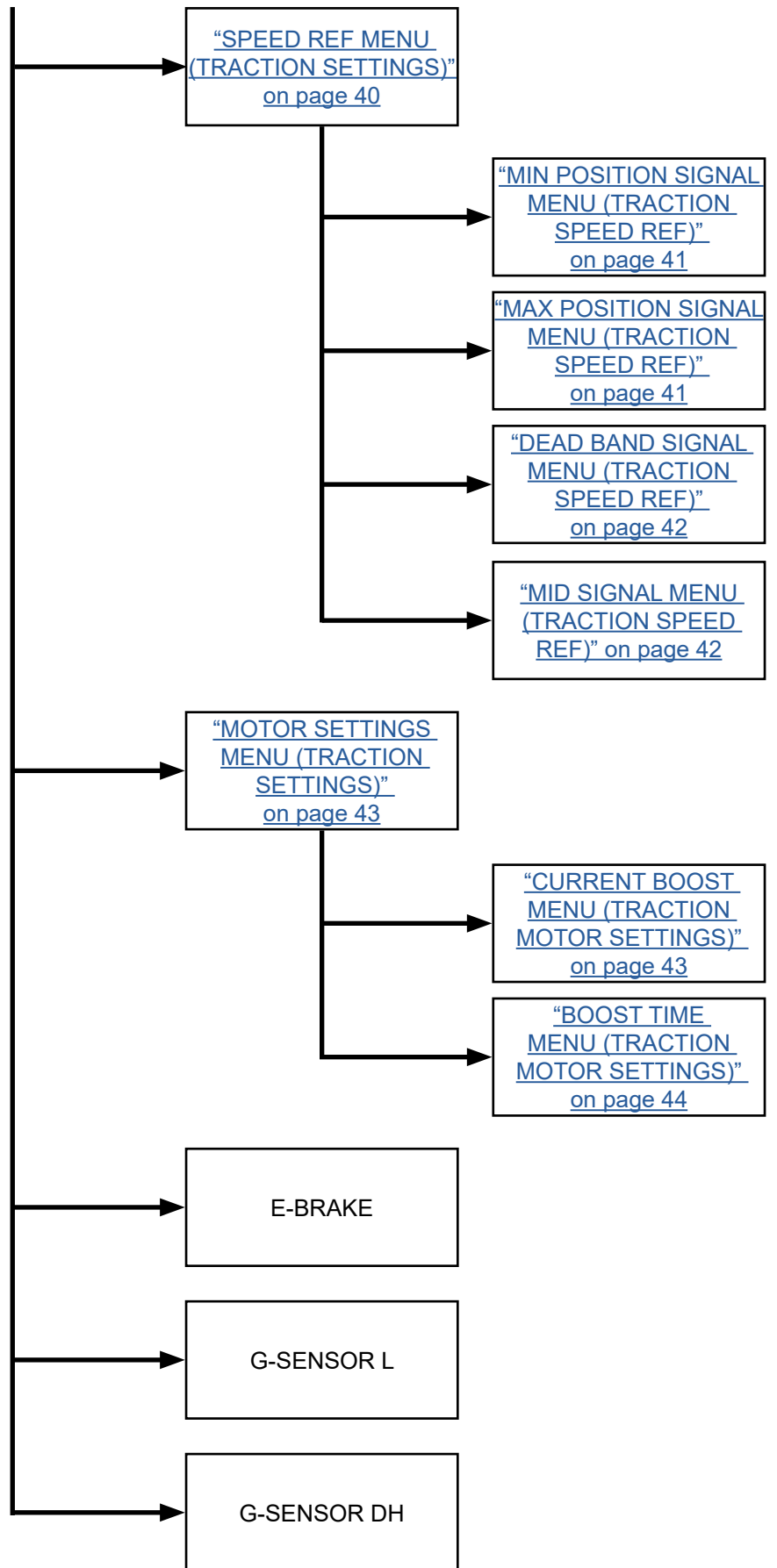

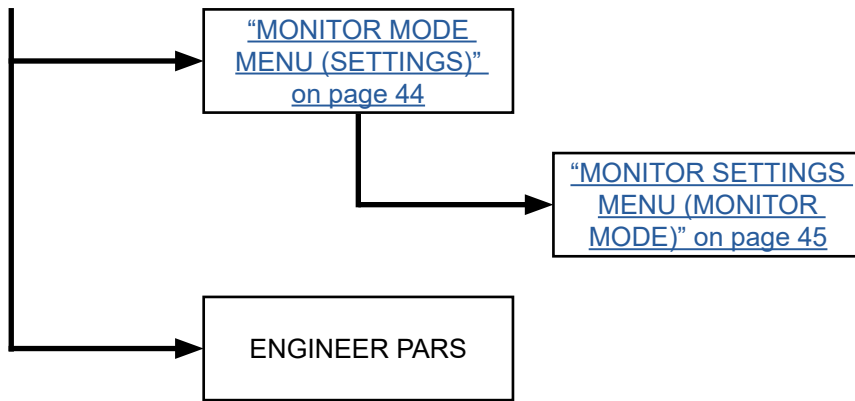

# SETTINGS MENU



Proceed as follows to view the “GENERAL MACHINE SETTINGS” menu:

1. Sit on the driver’s seat.
2. Press buttons (1) and (2) (**Fig. 1**) simultaneously. Keeping them pressed, switch on the machine by making a quarter turn clockwise with the key (1) (**Fig.2**).
3. After a few seconds, the “ID CHECK” screen will appear (**Fig.1**). Enter the password to access the “GENERAL MACHINE SETTINGS” menu.

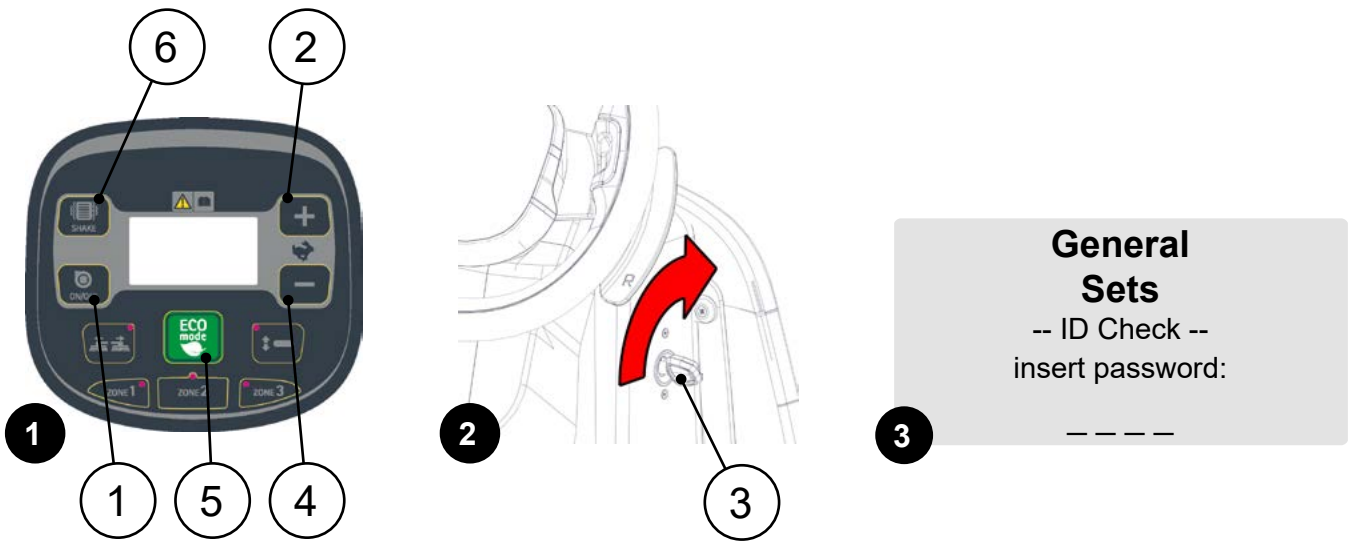
**i N.B.:** to access the assistance menu, at least CUSTOMER password level is required. See [“PASSWORD 3 CUSTOM MENU \(GENERAL ACCESS MODE\)” on page 19](#). If the password entered is correct, you will be taken to the “SETTINGS MENU”.

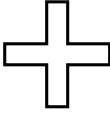
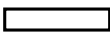

To navigate through the menus, use the buttons:

 <b>SHAKE</b>	the “SHAKE” symbol is used to scroll up
 <b>ON/OFF</b>	the “ON/OFF” symbol is used to scroll down
 <b>ECO mode</b>	the “ECO mode” symbol is used to confirm the selection, or to confirm the modification made
	the “+” symbol is used to increase the value
	the “-” symbol is used to decrease the value

**i** **N.B.:** when navigating the configuration menu, all the machine functions, including traction, are deactivated.

The following sub-menus can be selected on the Settings menu screen:



<b>GENERAL SETS</b>	Used to view and/or change the general machine parameters. See <a href="#">“GENERAL SETTINGS MENU (SETTINGS)” on page 14.</a>
<b>BRUSHES SETS</b>	Used to view and/or change the parameters of the machine's sweeping head. See <a href="#">“BRUSH SETTINGS MENU (SETTINGS)” on page 25.</a>
<b>VACUUM SETS</b>	Used to view and/or change the parameters of the machine's vacuum system. See <a href="#">“VACUUM SETTINGS MENU (SETTINGS)” on page 28.</a>
<b>OPTIONAL SETS</b>	Used to view and/or change the parameters relating to the various machine optionals. See <a href="#">“OPTIONAL SETTINGS MENU (SETTINGS)” on page 30.</a>
<b>ACTUATOR SETS</b>	It is not possible to access it because the “CUSTOMER” level password is not enabled to do so.
<b>TRACTION SETS</b>	Used to view and/or change the parameters relating to the machine's traction system. See <a href="#">“TRACTION SETTINGS MENU (SETTINGS)” on page 32.</a>
<b>MONITOR MODE</b>	Used to view the instantaneous machine values. See <a href="#">“MONITOR MODE MENU (SETTINGS)” on page 44.</a>
<b>ENGINEER PARS</b>	It is not possible to access it because the “CUSTOMER” level password is not enabled to do so.
<b>EXIT</b>	Used to quit the menu you are in, and return to the work screen.

## GENERAL SETTINGS MENU (SETTINGS)

### -SETTINGS-

General sets...

Proceed as follows to view the “GENERAL SETS” menu:

1. Display the “SETTINGS MENU” menu. See [“SETTINGS MENU” on page 12.](#)
2. Use the  and  buttons to select the “GENERAL SETTINGS” screen (see picture alongside), then press  to confirm.

 **N.B.:** in the parameters menu, the display is only shown in English.

The following sub-menus can be selected on the General menu screen:



<b>MAIN</b>	Used to view and/or change the parameters relating to the control display. See <a href="#">“MAIN MENU (GENERAL SETS)” on page 14.</a>
<b>BATTERY</b>	Used to select the type of battery that powers the machine. See <a href="#">“BATTERY MENU (GENERAL SETS)” on page 16.</a>
<b>HOURLMETER</b>	Used to change the type of hour meter selected on the main machine display. See <a href="#">“HOUR METER MENU (GENERAL SETS)” on page 17.</a>
<b>ACCESS MODE</b>	Used to change the CUSTOMER level password. See <a href="#">“ACCESS MODE MENU (GENERAL SETS)” on page 19.</a>
<b>SERVICE</b>	It is not possible to access it because the “CUSTOMER” level password is not enabled to do so.
<b>CONFIG</b>	Used to enable the optionals installed on the machine. See <a href="#">“CONFIG MENU (GENERAL SETS)” on page 22.</a>
<b>EXIT</b>	Used to quit the menu you are in, and return to the previous one.

## MAIN MENU (GENERAL SETS)

### General

Main

Proceed as follows to view the “MAIN” menu:

1. View the “GENERAL SETTINGS” menu. See [“GENERAL SETTINGS MENU \(SETTINGS\)” on page 14.](#)
2. Use the  and  buttons to select the “Main GENERAL” screen (see picture alongside), then press  to confirm.

The following personalised selections can be made on the main menu screen:

<b>LANGUAGE</b>	Used to change the language on the control display. See <a href="#">“LANGUAGE SELECTION MENU (GENERAL MAIN)” on page 15.</a>
<b>DISPLAY TUNE</b>	Used to adjust the control display contrast. See <a href="#">“DISPLAY TUNE MENU (GENERAL MAIN)” on page 15.</a>
<b>DISPLAY BRIGHTNESS</b>	Used to adjust the control display brightness. See <a href="#">“DISPLAY BRIGHTNESS MENU (GENERAL MAIN)” on page 16.</a>

## LANGUAGE SELECTION MENU (GENERAL MAIN)

### General





Main

Language selection:

ITA

1

Proceed as follows to change the display language:

1. Display the "MAIN" menu, see ["MAIN MENU \(GENERAL SETS\)" on page 14.](#)
2. Use the  and  buttons to select the "LANGUAGE SELECTION" screen (see picture alongside).
3. Use the  and  buttons to select the control display language.

**i** **N.B.:** the selected language will be visible in the text string (1) in the lower part of the screen.

4. Press  to confirm.

The following languages can be selected in the language menu:

ENG	English
ITA	Italian
FRA	French
GER	German
ESP	Spanish

**i** **N.B.:** changing the language displays the text strings of the menu and alarms in the selected language.

## DISPLAY TUNE MENU (GENERAL MAIN)

### General

Main

Display tune:





min:0

15

max:50

1

To adjust the display contrast, proceed as follows:

1. Display the "MAIN" menu, see ["MAIN MENU \(GENERAL SETS\)" on page 14.](#)
2. Use the  and  buttons to select the "DISPLAY TUNE" screen (see picture alongside).
3. Use the  and  buttons to adjust the control display contrast.

**i** **N.B.:** the control display contrast level will be visible in the text string (1) in the lower part of the screen.

**i** **N.B.:** the contrast level is increased in steps of 1 unit; the minimum value allowed is 0 and the maximum is 50.

4. Press  to confirm.

## DISPLAY BRIGHTNESS MENU (GENERAL MAIN)

### General

Main

Display brightness:

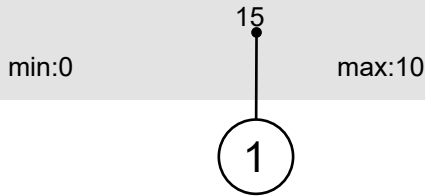

To adjust the display contrast, proceed as follows:

1. Display the “MAIN” menu, see [“MAIN MENU \(GENERAL SETS\)” on page 14](#).

2. Use the and buttons to select the “DISPLAY BRIGHTNESS” screen (see picture alongside).

3. Use the and buttons to adjust the control display brightness.

**i** **N.B.:** the control display brightness level will be visible in the text string (1) in the lower part of the screen.

**i** **N.B.:** the brightness level is increased in steps of 1 unit; the minimum value allowed is 0 and the maximum is 50.

4. Press to confirm.

## BATTERY MENU (GENERAL SETS)

### General

Battery

Proceed as follows to view the “BATTERY” menu:

1. View the “GENERAL SETTINGS” menu. See [“GENERAL SETTINGS MENU \(SETTINGS\)” on page 14](#).

2. Use the and buttons to select the “Battery GENERAL” screen (see picture alongside), then press to confirm.

The following personalised selections can be made on the battery menu screen:

<b>BATTERY TYPE</b>	Used to change the type of battery that powers the machine. See <a href="#">“BATTERY TYPE MENU (GENERAL BATTERY)” on page 16</a> .
<b>CUSTOM LEVEL</b>	Used to adjust the discharge curve of the type of custom battery. See <a href="#">“CUSTOM LEVEL MENU (GENERAL BATTERY)” on page 17</a> .

## BATTERY TYPE MENU (GENERAL BATTERY)

### General

Battery

Battery Type:

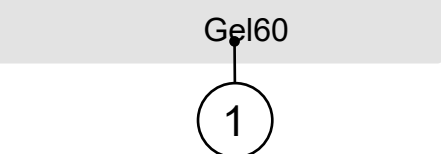

To change the type of power supply battery of the machine, proceed as follows:

1. View the “BATTERY” menu. See [“BATTERY MENU \(GENERAL SETS\)” on page 16](#).

2. Use the and buttons to select the “BATTERY TYPE” screen (see picture alongside).

3. Use the and buttons to select the type of battery required.

**i** **N.B.:** the selected battery type will be visible in the text string (1) in the lower part of the screen.

4. Press to confirm.

The following can be selected in the battery type selection menu:

Pb60	Gel80
Gel60	Custom
Pure Lead	LiPo
Pb80	

**N.B.:** the standard battery type selected is Gel60.

## CUSTOM LEVEL MENU (GENERAL BATTERY)

### General

Battery

Custom level 5/5:

min:15.0      33.5 [V]      max:40.0

1

Proceed as follows to change the type of custom battery discharge curve:

1. View the "BATTERY" menu. See ["BATTERY MENU \(GENERAL SETS\)" on page 16.](#)
2. Use the and buttons to select the "CUSTOM LEVEL" screen (see picture alongside).
3. Use the and buttons to adjust the discharge voltage value.

**N.B.:** the battery discharge voltage will be visible in the text string (1) in the lower part of the screen.

4. Press to confirm.

**N.B.:** the voltage is increased in steps of 0.1V; the minimum value allowed is 15.0 and the maximum is 40.0.

**N.B.:** to create the discharge curve, there are six levels to enter, from Custom Level 5/5 to Custom Level 0/5.

**N.B.:** the voltage defined in the factory is 23.5V for Custom Level value 5/5; 23.0V for Custom Level value 4/5; 22.5V for Custom Level value 3/5; 22.0V for Custom Level value 2/5; 21.5V for Custom Level value 1/5; 21.0V for Custom Level value 0/5.

## HOUR METER MENU (GENERAL SETS)

### General

Hourmeter

Proceed as follows to view the "HOUR METER" menu:

1. View the "GENERAL SETTINGS" menu. See ["GENERAL SETTINGS MENU \(SETTINGS\)" on page 14.](#)
2. Use the and buttons to select the "Hour meter GENERAL" screen (see picture alongside), then press to confirm.

The following personalised selections can be made on the hour meter menu screen:

<b>PARTIAL HMR TO DISPLAY</b>	Used to change the type of partial hour meter shown on the control display. See <a href="#">“PARTIAL HMR O DISPLAY MENU (GENERAL HOUR METER)” on page 18.</a>
<b>RESET PARTIAL HMR</b>	Used to reset the partial hour meter shown on the control display. See <a href="#">“PARTIAL HMR RESET MENU (GENERAL HOUR METER)” on page 18.</a>

## PARTIAL HMR O DISPLAY MENU (GENERAL HOUR METER)

### General

Hourmeter

Visualized hmt:

Tr

To change the type of hour meter displayed on the machine's control display, proceed as follows:

1. Display the “HOURMETER” menu, see [“HOUR METER MENU \(GENERAL SETS\)” on page 17.](#)
2. Use the and buttons to select the “PARTIAL HMR TO DISPLAY” screen (see picture alongside).
3. Use the and buttons to select the type of hour meter to be shown on the control display.

**N.B.:** the selected hour meter will be visible in the text string (1) in the lower part of the screen.

4. Press to confirm.

The following can be selected in the hour meter type selection menu:

Key	hour meter for the machine's starter key
Tr	hour meter for the machine's traction motor
Br	hour meter for the machine's brush motor
Vac	hour meter for the machine's suction motor

**N.B.:** the partial hour meter defined in the factory is the one relating to machine traction (Tr).

## PARTIAL HMR RESET MENU (GENERAL HOUR METER)

### General

Hourmeter

Reset PARTIAL hmt:

No.

To reset the partial hour meter of the machine, proceed as follows:

1. Display the “HOURMETER” menu. See [“HOUR METER MENU \(GENERAL SETS\)” on page 17.](#)
2. Use the and buttons to select the “PARTIAL HMR RESET” screen (see picture alongside).
3. Use the and buttons to select the type of hour meter you want to reset.

**N.B.:** the type of partial hour meter to be reset will be visible in the text string (1) in the lower part of the screen.

4. Press to confirm.

The following can be selected in the partial hour meter type selection menu:

No	no partial hour meter will be reset
Key	only the partial hour meter related to the machine's starter key will be reset
Tr	only the partial hour meter related to the machine's traction motor will be reset
Br	only the partial hour meter related to the machine's brush motor will be reset
Vac	only the partial hour meter related to the machine's suction motor will be reset
All	all partial hour meters will be reset

## ACCESS MODE MENU (GENERAL SETS)

### General AccessMode

Proceed as follows to view the "ACCESS MODE" menu:

1. View the "GENERAL SETTINGS" menu. See ["GENERAL SETTINGS MENU \(SETTINGS\)" on page 14.](#)
2. Use the and buttons to select the "Access Mode GENERAL" screen (see picture alongside), then press to confirm.

The following personalised selections can be made on the access mode menu screen:

<b>PASSWORD 3 (CUSTOM)</b>	Used to change the custom level password. See <a href="#">"PASSWORD 3 CUSTOM MENU (GENERAL ACCESS MODE)" on page 19.</a>
<b>PASSWORD 4 (USER)</b>	Used to change the user level password. See <a href="#">"PASSWORD 4 USER MENU (GENERAL ACCESS MODE)" on page 20.</a>
<b>PASSWORD 5 (PIN)</b>	Used to change the pin level password. See <a href="#">"PASSWORD 5 PIN MENU (GENERAL ACCESS MODE)" on page 20.</a>
<b>PASSWORD PROT USER</b>	Used to activate/deactivate the user level password. See <a href="#">"PROT USER PASSWORD MENU (GENERAL ACCESS MODE)" on page 21.</a>
<b>PASSWORD PROT PIN</b>	Used to activate/deactivate the pin level password. See <a href="#">"PROT PIN PASSWORD MENU (GENERAL ACCESS MODE)" on page 21.</a>

## PASSWORD 3 CUSTOM MENU (GENERAL ACCESS MODE)

### General AccessMode

Password 3 custom:

min:2000

2234

max:2999

1

To change the level 3 (Customer) password, proceed as follows:

1. Display the "ACCESS MODE" menu. See ["ACCESS MODE MENU \(GENERAL SETS\)" on page 19.](#)
2. Use the and buttons to select the "PASSWORD 3 CUSTOM" screen (see picture alongside).
3. Use the and buttons to enter the new password you want to use.

**N.B.:** the level 3 password will be visible in the text string (1) in the lower part of the screen.

4. Press to confirm.

**i** **N.B.:** the password set in the factory is 2234, the new password must be between 2000 and 2999.

**i** **N.B.:** the CUSTOMER level password makes it possible to change the parameters for the machine functions.

## PASSWORD 4 USER MENU (GENERAL ACCESS MODE)

### General

AccessMode



Password 4 user:



min:1000      1000      max:1999

(1)

To change the level 4 password (User), proceed as follows:

1. Display the "ACCESS MODE" menu, see ["ACCESS MODE MENU \(GENERAL SETS\)" on page 19.](#)

2. Use the  and  buttons to select the "PASSWORD 4 USER" screen (see picture alongside).

3. Use the  and  buttons to enter the new password you want to use.

**i** **N.B.:** the level 4 password will be visible in the text string (1) in the lower part of the screen.

4. Press  to confirm.

**i** **N.B.:** the password set in the factory is 1000, the new password must be between 1000 and 1999.

## PASSWORD 5 PIN MENU (GENERAL ACCESS MODE)

### General

AccessMode



Password 5 pin:



min:100      123      max:999

(1)

To change the level 5 "PIN" password, proceed as follows:

1. Display the "ACCESS MODE" menu. See ["ACCESS MODE MENU \(GENERAL SETS\)" on page 19.](#)

2. Use the  and  buttons to select the "PASSWORD 5 PIN" screen (see picture alongside).

3. Use the  and  buttons to enter the new password you want to use.

**i** **N.B.:** the level 5 password will be visible in the text string (1) in the lower part of the screen.

4. Press  to confirm.

**i** **N.B.:** the password set in the factory is 123, the new password must be between 100 and 999.

## PROT USER PASSWORD MENU (GENERAL ACCESS MODE)

### General

AccessMode

Password prot User:

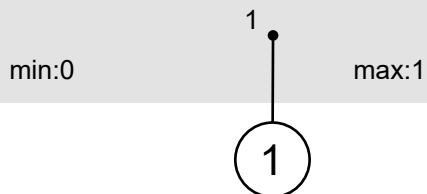

To activate or deactivate the USER level password request, proceed as follows:

1. Display the "ACCESS MODE" menu. See ["ACCESS MODE MENU \(GENERAL SETS\)" on page 19](#).
2. Use the and buttons to select the "PASSWORD PROT USER" screen (see picture alongside).
3. Use the and buttons to choose whether or not to activate the user level password.

**N.B.:** the selected value will be visible in the text string (1) in the lower part of the screen.

4. Press to confirm.

**N.B.:** by selecting "0" the password will not be active, therefore it is possible to freely access the functions in the "SETTINGS" menu.

**N.B.:** by selecting "1" the password will be active, therefore the functions in the "SETTINGS" menu can only be accessed if the USER password is entered (the factory setting is 1000).

## PROT PIN PASSWORD MENU (GENERAL ACCESS MODE)

### General

AccessMode

Password prot Pin:

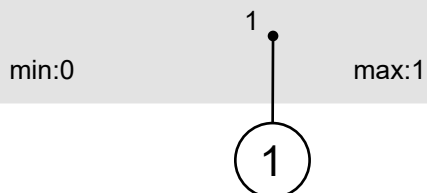

To activate or deactivate the USER level password request, proceed as follows:

1. Display the "ACCESS MODE" menu. See ["ACCESS MODE MENU \(GENERAL SETS\)" on page 19](#).
2. Use the and buttons to select the "PASSWORD PROT PIN" screen (see picture alongside).
3. Use the and buttons to choose whether or not to activate the pin level password.

**N.B.:** the selected value will be visible in the text string (1) in the lower part of the screen.

4. Press to confirm.

**N.B.:** by selecting "0", the password will not be active, therefore the machine can be used without entering a password after it starts.



**N.B.:** by selecting "1", the password is active, therefore to be able to use the machine a PIN password must be entered after the machine starts (the factory value is 123).

## CONFIG MENU (GENERAL SETS)

### General

#### Config

Proceed as follows to view the “ACCESS MODE” menu:

1. View the “GENERAL SETTINGS” menu. See [“GENERAL SETTINGS MENU \(SETTINGS\)” on page 14.](#)
2. Use the  and  buttons to select the “GENERAL Config” screen (see picture alongside), then press  to confirm.

The following personalised selections can be made on the config menu screen:

<b>WORKLIGHT ENABLE</b>	Used to enable the worklights on the machine. See <a href="#">“WORKLIGHT ENABLING MENU (GENERAL CONFIG)” on page 22.</a>
<b>ANTICOLLISION ENABLE</b>	Used to enable the anti-collision system on the machine. See <a href="#">“ANTI-COLLISION MENU (GENERAL CONFIG)” on page 23.</a>
<b>HAZARD LIGHTS</b>	Used to enable the emergency lights function. See <a href="#">“HAZARD LIGHTS MENU (GENERAL CONFIG)” on page 23.</a>
<b>MANUAL OP ENABLE</b>	Used to activate the MANUAL MODE working program. See <a href="#">“MANUAL OP ENABLING MENU (GENERAL CONFIG)” on page 24.</a>
<b>ZONE OP ENABLE</b>	Used to activate the ZONE MODE working program. See <a href="#">“ZONE OP ENABLING MENU (GENERAL CONFIG)” on page 24.</a>

## WORKLIGHT ENABLING MENU (GENERAL CONFIG)

### General

#### Config





Worklight

Enable:

YES

1

To activate or deactivate the worklights on the machine, proceed as follows:

1. Display the “CONFIG” menu. See [“CONFIG MENU \(GENERAL SETS\)” on page 22.](#)
2. Use the  and  buttons to select the “WORKLIGHT ENABLING” screen (see picture alongside).
3. Use the  and  buttons to choose whether or not to activate the worklights.

**i** **N.B.:** the selected value will be visible in the text string (1) in the lower part of the screen.

4. Press  to confirm.

**i** **N.B.:** selecting “NO”, the worklights will not be active. Selecting “YES”, the worklights will be activated every time the machine is switched on.





## ANTI-COLLISION MENU (GENERAL CONFIG)

### General Config

Anticollision: NO

1

To activate or deactivate the anti-collision system on the machine, proceed as follows:

1. Display the "CONFIG" menu. See ["CONFIG MENU \(GENERAL SETS\)" on page 22](#).
2. Use the  and  buttons to select the "ANTI-COLLISION" screen (see picture alongside).
3. Use the  and  buttons to choose whether or not to activate the anti-collision system on the machine.

 **N.B.:** the selected value will be visible in the text string (1) in the lower part of the screen.

4. Press  to confirm.

The following can be selected in the anti-collision function management menu:

NO	deactivates the function.
YES	activates the function with the aid of the integrated acoustic warning system.
BRAKE	activates the function, in addition to the aid of the integrated acoustic warning system, there is also the assisted braking system.

## HAZARD LIGHTS MENU (GENERAL CONFIG)





### General Config

Hazard  
Lights:

NO

1

To activate or deactivate the worklight blinking effect, proceed as follows:

1. Display the "CONFIG" menu. See ["CONFIG MENU \(GENERAL SETS\)" on page 22](#).
2. Use the  and  buttons to select the "HAZARD LIGHTS" screen (see picture alongside).
3. Use the  and  buttons to choose whether or not to activate the blinking function for the worklights.

 **N.B.:** the selected value will be visible in the text string (1) in the lower part of the screen.

4. Press  to confirm.

 **N.B.:** by selecting "NO" the hazard lights function will not be active. In this way, both the headlights and the rear lights will be active while working, but will not blink.

 **N.B.:** by selecting "YES" the hazard lights function will be active, in this way both the front lights as well as the rear lights will be active while working with a blinking light effect.

## MANUAL OP ENABLING MENU (GENERAL CONFIG)

### General





Config

Manual Op

Enable: YES

1

To activate or deactivate the MANUAL MODE working program, proceed as follows:

1. Display the “CONFIG” menu. See [“CONFIG MENU \(GENERAL SETS\)” on page 22.](#)
2. Use the  and  buttons to select the “MANUAL OP ENABLING” screen (see picture alongside).
3. Use the  and  buttons to choose whether or not to activate the manual working program.

**i** **N.B.:** the selected value will be visible in the text string (1) in the lower part of the screen.

4. Press  to confirm.

**i** **N.B.:** selecting “NO”, the MANUAL MODE working program will be disabled; selecting “YES”, the program will be enabled. For more information about the MANUAL MODE program, see “MANUAL MODE WORKING PROGRAM” in the “USE AND MAINTENANCE MANUAL” consigned with the machine documentation.

## ZONE OP ENABLING MENU (GENERAL CONFIG)

### General





Config

Zone Op

Enable: YES

1

To activate or deactivate the ZONE PROGRAM working program, proceed as follows:

1. Display the “CONFIG” menu. See [“CONFIG MENU \(GENERAL SETS\)” on page 22.](#)
2. Use the  and  buttons to select the “ZONE OP ENABLING” screen (see picture alongside).
3. Use the  and  buttons to choose whether or not to activate the zone program working program.

**i** **N.B.:** the selected value will be visible in the text string (1) in the lower part of the screen.

4. Press  to confirm.



**i** **N.B.:** selecting “NO”, the ZONE PROGRAM working program will be disabled; selecting “YES”, the program will be enabled. For more information about ZONE PROGRAM, see “PROGRAM ZONE WORKING PROGRAM” in the “USE AND MAINTENANCE MANUAL” consigned with the machine documentation.

## BRUSH SETTINGS MENU (SETTINGS)

### -SETTINGS-

Brushes  
sets...

Proceed as follows to view the “BRUSHES SETS” menu:

1. Display the “SETTINGS MENU” menu. See [“SETTINGS MENU” on page 12.](#)
2. Use the  and  buttons to select the “BRUSH SETTINGS” screen (see picture alongside), then press  to confirm.

 **N.B.:** in the parameters menu, the display is only shown in English.

The following sub-menus can be selected on the Brushes menu screen:



<b>BRUSHMOTOR</b>	Used to change the parameters relating to the machine's sweeping head. See <a href="#">“BRUSHMOTOR MENU (BRUSH SETTINGS)” on page 25.</a>
<b>EXIT</b>	Used to quit the menu you are in, and return to the previous one.

## BRUSHMOTOR MENU (BRUSH SETTINGS)

### Brushes

BrushMotor

To view the “BRUSHMOTOR” menu, proceed as follows:

1. View the “BRUSH SETTINGS” menu. See [“BRUSH SETTINGS MENU \(SETTINGS\)” on page 25.](#)
2. Use the  and  buttons to select the “Brushmotor” screen (see picture alongside), then press  to confirm.

The following personalised selections can be made on the brushmotor menu screen:

<b>RESET DELAY</b>	Used to change the parameter for the standby time before the actuator moves the sweeping brush head into the "lifted off the floor" position. See <a href="#">“DELAY RESET MENU (BRUSHES BRUSHMOTOR)” on page 26.</a>
<b>SPEED REDUCTION</b>	Used to change the parameter for voltage reset from an ammeter protection tripping condition. See <a href="#">“SPEED REDUCTION MENU (BRUSHES BRUSHMOTOR)” on page 26.</a>
<b>PRESSURE LEVEL</b>	Used to change the parameter for the pressure levels exerted on the scrubbing brush head. See <a href="#">“PRESSURE LEVEL MENU (BRUSHES BRUSHMOTOR)” on page 27.</a>
<b>PRESSURE RANGE</b>	Used to change the parameter for the maximum current interval permitted for the pressure levels prior to the tripping of the ammeter protection. See <a href="#">“PRESSURE RANGE MENU (BRUSHES BRUSHMOTOR)” on page 27.</a>

## DELAY RESET MENU (BRUSHES BRUSHMOTOR)

### Brushes





Brush Mot

Reset delay:

min:1      20      [s]      max:300

1

Proceed as follows to change the “RESET DELAY” parameter in the brush motor menu:

1. View the “BRUSHMOTOR” menu. See [“BRUSHMOTOR MENU \(BRUSH SETTINGS\)” on page 25.](#)
2. Use the  and  buttons to select the “DELAY RESET” screen (see picture alongside).
3. Use the  and  buttons to select the standby seconds before the actuator moves the brush head to the “lifted off the floor” position.

 **N.B.:** the selected value will be visible in the text string (1) in the lower part of the screen.

4. Press  to confirm.

 **N.B.:** the “DELAY RESET” parameter represents the standby time before the actuator moves the sweeping brush head into the “lifted off the floor” position.

 **N.B.:** the “DELAY RESET” parameter is expressed in seconds (s), the numerical value is between a minimum of 001 and a maximum of 300, the selectable increment is one unit.

 **N.B.:** the “DELAY RESET” parameter is set in the factory to 20.

## SPEED REDUCTION MENU (BRUSHES BRUSHMOTOR)

### Brushes





Brush Mot

Speed Reduction:

min:15      24      [V]      max:24

1

Proceed as follows to change the “SPEED REDUCTION” parameter in the brush motor menu:

1. View the “BRUSHMOTOR” menu. See [“BRUSHMOTOR MENU \(BRUSH SETTINGS\)” on page 25.](#)
2. Use the  and  buttons to select the “SPEED REDUCTION” screen (see picture alongside).
3. Use the  and  buttons to select the reset voltage for the gearmotor in the brush head.

 **N.B.:** the selected value will be visible in the text string (1) in the lower part of the screen.

4. Press  to confirm.

 **N.B.:** the “SPEED REDUCTION” parameter represents the recovery voltage from the ammeter protection tripping condition.

 **N.B.:** the “SPEED REDUCTION” parameter is expressed in Volt (V). The numerical value is between a minimum of 015 and a maximum of 024, in increments of one unit.

 **N.B.:** the “SPEED REDUCTION” parameter is set in the factory to 24.

## PRESSURE LEVEL MENU (BRUSHES BRUSHMOTOR)

### Brushes

Brush Mot

Pressure Lev. 1:

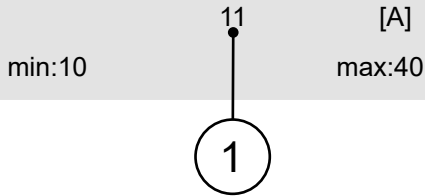

Proceed as follows to change the “PRESSURE LEVEL” parameter in the brush motor menu:

1. View the “BRUSHMOTOR” menu. See [“BRUSHMOTOR MENU \(BRUSH SETTINGS\)” on page 25.](#)
2. Use the and buttons to select the “PRESSURE LEVEL” screen (see picture alongside).
3. Use the and buttons to select the current drawn by the brush head unit when working.

**N.B.:** the selected value will be visible in the text string (1) in the lower part of the screen.

4. Press to confirm.

**N.B.:** the “PRESSURE LEVEL” parameters represent the value of the current drawn by the sweeping brush head while working.

**N.B.:** the “PRESSURE LEVEL” parameters correspond to the pressure levels exerted on the brush head in the three work zones saved in the machine function board memory. See “PROGRAM ZONE WORKING PROGRAM” present in the “USE AND MAINTENANCE MANUAL” delivered with the machine documentation.

**N.B.:** the “PRESSURE LEVEL” parameters are expressed in amperes (A). The numeric values are between a minimum of 10 and a maximum of 40, with increments of one unit.

**N.B.:** the “PRESSURE LEVEL” parameters are factory set with the following values:

- PRESSURE LEVEL #1= 11
- PRESSURE LEVEL #2= 13
- PRESSURE LEVEL #3= 15

## PRESSURE RANGE MENU (BRUSHES BRUSHMOTOR)

### Brushes

Brush Mot

Pressure Range:

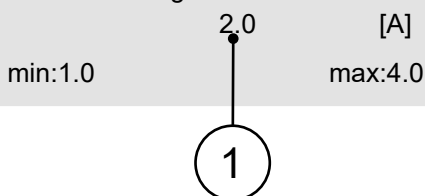

Proceed as follows to change the “PRESSURE RANGE” parameter in the brush motor menu:

1. View the “BRUSHMOTOR” menu. See [“BRUSHMOTOR MENU \(BRUSH SETTINGS\)” on page 25.](#)
2. Use the and buttons to select the “PRESSURE RANGE” screen (see picture alongside).
3. Use the and buttons to select the value of the maximum interval permitted for the current drawn by the pressure levels before the tripping of the ammeter resistance protection.

**N.B.:** the selected value will be visible in the text string (1) in the lower part of the screen.

4. Press to confirm.

**N.B.:** the “PRESSURE RANGE” parameter represents the value of the maximum interval permitted for the current absorbed by the pressure levels before the tripping of the ammeter resistance protection (while working).



**i** **N.B.:** the “PRESSURE RANGE” parameter is expressed in amperes (A). The numerical value is between a minimum of 1.0 and a maximum of 4.0, with increments of five tenths of a unit.

**i** **N.B.:** the “PRESSURE RANGE” parameter is factory set at 2.0.

## VACUUM SETTINGS MENU (SETTINGS)



Proceed as follows to display the “VACUUM SETS” menu:

1. Display the “SETTINGS MENU” menu. See [“SETTINGS MENU” on page 12.](#)
2. Use the  and  buttons to select the “VACUUM SETTINGS” screen (see picture alongside), then press  to confirm.

**i** **N.B.:** in the parameters menu, the display is only shown in English.



The following sub-menus can be selected on the Vacuum menu screen:

<b>VAC. MOTOR</b>	Used to adjust the parameters of the machine's vacuum head. See <a href="#">“VAC. MOTOR MENU (VACUUM SETTINGS)” on page 28.</a>
<b>SHAKE MOTOR</b>	Used to adjust the parameters of the machine's vacuum filter unit. See <a href="#">“SHAKE MOTOR MENU (VACUUM SETTINGS)” on page 29.</a>
<b>EXIT</b>	Used to quit the menu you are in, and return to the previous one.

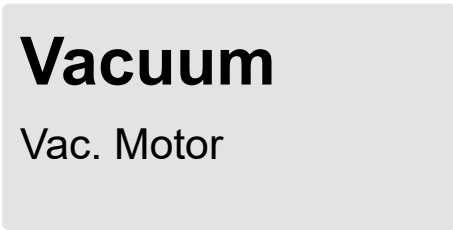
## VAC. MOTOR MENU (VACUUM SETTINGS)



Proceed as follows to view the “VAC. MOTOR” menu:

1. View the “VACUUM SETTINGS” menu. See [“VACUUM SETTINGS MENU \(SETTINGS\)” on page 28.](#)
2. Use the  and  buttons to select the “Vacuum motor” screen (see picture alongside), then press  to confirm.

The following personalised selections can be made on the vacuum motor menu screen:

<b>VAC. NOISE LEVEL</b>	Used to modify the parameter for the performance of the machine's suction motor. See <a href="#">“VACUUM NOISE LEVEL MENU (VACUUM MOTOR)” on page 29.</a>
-------------------------	---

## VACUUM NOISE LEVEL MENU (VACUUM MOTOR)

### Vacuum

Vac. Motor

Vac. Noise Level 1:

min:12      20 [V]      max:24



To change the “VACUUM NOISE LEVEL” parameter in the Vacuum Motor menu, proceed as follows:

1. View the “VACUUM MOTOR” menu. See [“VAC. MOTOR MENU \(VACUUM SETTINGS\)” on page 28.](#)
2. Use the and buttons to select the “VACUUM NOISE LEVEL” screen (see picture alongside).
3. Use the and buttons to select the current drawn by the suction motor when working.

**N.B.:** the selected value will be visible in the text string (1) in the lower part of the screen.

4. Press to confirm.

**N.B.:** the “VACUUM NOISE LEVEL” parameters represent the value of the current drawn by the suction motor while working.

**N.B.:** the “VACUUM NOISE LEVEL” parameters correspond to the vacuum performance levels in the three work zones saved in the machine function board memory. See “PROGRAM ZONE WORKING PROGRAM” present in the “USE AND MAINTENANCE MANUAL” delivered with the machine documentation.

**N.B.:** the “VACUUM NOISE LEVEL” parameters are expressed in Volt (V). The numeric values are between a minimum of 12 and a maximum of 24, with increments of one unit.

**N.B.:** the “VACUUM NOISE LEVEL” parameters are factory set at the following values:

- VAC. NOISE LEVEL #1= 20
- VAC. NOISE LEVEL #2= 22
- VAC. NOISE LEVEL #3= 24

## SHAKE MOTOR MENU (VACUUM SETTINGS)

### Vacuum

Shake Motor

To view the “SHAKE MOTOR” menu, proceed as follows:

1. View the “VACUUM SETTINGS” menu. See [“VACUUM SETTINGS MENU \(SETTINGS\)” on page 28.](#)
2. Use the and buttons to select the “Shake motor” screen (see picture alongside), then press to confirm.

The following personalised selections can be made on the shake motor menu screen:

<b>SHAKE MOTOR FREQ.</b>	Used to change the parameter for the filter shaker activation frequency. See <a href="#">“SHAKE MOTOR FREQUENCY MENU (VACUUM SHAKE MOTOR)” on page 30.</a>
--------------------------	--

## SHAKE MOTOR FREQUENCY MENU (VACUUM SHAKE MOTOR)

### Vacuum





Shake Motor

Shake Motor Freq. 1:

min:5      15 [min]      max:60



To change the “SHAKE MOTOR FREQUENCY” parameter in the shake motor menu, proceed as follows:

1. View the “SHAKE MOTOR” menu. See [“SHAKE MOTOR MENU \(VACUUM SETTINGS\)” on page 29.](#)
2. Use the  and  buttons to select the “SHAKE MOTOR FREQUENCY” screen (see picture alongside).
3. Use the  and  buttons to select the pause time between one filter shaker activation and the next while working.

**i** **N.B.:** the selected value will be visible in the text string (1) in the lower part of the screen.

4. Press  to confirm.

**i** **N.B.:** the “SHAKE MOTOR FREQUENCY” parameters represent the pause minutes between one filter shaker activation and the next while working.

**i** **N.B.:** the “SHAKE MOTOR FREQUENCY” parameters correspond to the vacuum performance levels in the three work zones saved in the machine function board memory. See “ADJUSTING THE FILTER SHAKER MODE” present in the “USE AND MAINTENANCE MANUAL” delivered with the machine documentation.

**i** **N.B.:** the “SHAKE MOTOR FREQUENCY” parameters are expressed in minutes (min). The numeric values are between a minimum of 5 and a maximum of 60, with increments of one unit.

**i** **N.B.:** the “SHAKE MOTOR FREQUENCY” parameters are factory set with the following values:



- SHAKE MOTOR FREQ. #1= 15
- SHAKE MOTOR FREQ. #2= 10
- SHAKE MOTOR FREQ. #3= 05

## OPTIONAL SETTINGS MENU (SETTINGS)

### -SETTINGS-

Optional sets...

Proceed as follows to display the “OPTIONAL SETS” menu:

1. Display the “SETTINGS MENU” menu. See [“SETTINGS MENU” on page 12.](#)
2. Use the  and  buttons to select the “OPTIONAL SETTINGS” screen (see picture alongside), then press  to confirm.

**i** **N.B.:** in the parameters menu, the display is only shown in English.



The following sub-menus can be selected on the Optional menu screen:

<b>BRUSHFUNC.</b>	Used to adjust the parameters of the machine's side brush control unit. See <a href="#">“BRUSH FUNCTION MENU (OPTIONAL SETTINGS)” on page 31.</a>
<b>EXIT</b>	Used to quit the menu you are in, and return to the previous one.

## BRUSH FUNCTION MENU (OPTIONAL SETTINGS)

### Optional BrushFunc.

To view the “BRUSH FUNCTION” menu, proceed as follows:

1. View the “OPTIONAL SETTINGS” menu. See [“OPTIONAL SETTINGS MENU \(SETTINGS\)” on page 30.](#)
2. Use the  and  buttons to select the “Brush function” screen (see picture alongside), then press  to confirm.

The following personalised selections can be made on the brush function menu screen:

<b>BRUSHFUNC. RESET DELAY</b>	Used to change the parameter for the standby time before the actuator moves the side brush head into the “lifted off the floor” position. See <a href="#">“DELAY RESET MENU (BRUSHES BRUSHMOTOR)” on page 26.</a>
-----------------------------------	---

## DELAY RESET MENU (OPTIONAL BRUSH FUNCTION)





### Optional BrushFunc.

Reset delay:

min:1                      20                      [s]                      max:300





To change the “DELAY RESET” parameter in the brush function menu, proceed as follows:

1. View the “BRUSH FUNCTION” menu. See [“BRUSH FUNCTION MENU \(OPTIONAL SETTINGS\)” on page 31.](#)
2. Use the  and  buttons to select the “DELAY RESET” screen (see picture alongside).
3. Use the  and  buttons to select the standby seconds before the actuator moves the side brush to the “lifted off the floor” position.

 **N.B.:** the selected value will be visible in the text string (1) in the lower part of the screen.

4. Press  to confirm.

 **N.B.:** the “DELAY RESET” parameter represents the standby time before the actuator moves the side brush into the “lifted off the floor” position.

 **N.B.:** the “DELAY RESET” parameter is expressed in seconds (s), the numerical value is between a minimum of 001 and a maximum of 300, the selectable increment is one unit.



 **N.B.:** the “DELAY RESET” parameter is set in the factory to 20.

## TRACTION SETTINGS MENU (SETTINGS)

### -SETTINGS-

Traction  
sets...

<Proceed as follows to display the “TRACTION SETS” menu:

1. Display the “SETTINGS MENU” menu. See [“SETTINGS MENU” on page 12.](#)
2. Use the  and  buttons to select the “TRACTION SETTINGS” screen (see picture alongside), then press  to confirm.

 **N.B.:** in the parameters menu, the display is only shown in English.



The following sub-menus can be selected on the Traction menu screen:

<b>SPEED SETS</b>	Used to change the machine speed parameters. See <a href="#">“SPEED SETS MENU (TRACTION SETS)” on page 32.</a>
<b>SPEED REF</b>	Used to change the machine drive pedal parameters. See <a href="#">“SPEED REF MENU (TRACTION SETTINGS)” on page 40.</a>
<b>MOTOR SETS</b>	Used to change the parameters for the machine's traction motor.
<b>EXIT</b>	Used to quit the menu you are in, and return to the previous one.

## SPEED SETS MENU (TRACTION SETS)

**Traction**  
Speed Sets

<Proceed as follows to display the “SPEED SETS” menu:

1. View the “TRACTION SETTINGS” menu. See [“TRACTION SETTINGS MENU \(SETTINGS\)” on page 32.](#)
2. Use the  and  buttons to select the “Speed settings” screen (see picture alongside), then press  to confirm.

The following personalised selections can be made on the Speed settings menu screen:

<b>ACCELERATION RAMP #1</b>	Used to modify the time interval to reach the maximum speed (transfer mode). See <a href="#">“ACCELERATION RAMP #1 MENU (TRACTION SPEED SETTINGS)” on page 33.</a>
<b>ACCELERATION RAMP #2</b>	Used to modify the time interval to reach the maximum speed (work mode). See <a href="#">“ACCELERATION RAMP #2 MENU (TRACTION SPEED SETTINGS)” on page 34.</a>
<b>DECELERATION RAMP #1</b>	Used to modify the time interval to switch from the current speed to the set speed (with reduced pressure on the drive pedal in transfer mode). See <a href="#">“DECELERATION RAMP #1 MENU (TRACTION SPEED SETTINGS)” on page 34.</a>
<b>DECELERATION RAMP #2</b>	Used to modify the time interval to switch from the current speed to the set speed (with reduced pressure on the drive pedal in work mode). See <a href="#">“DECELERATION RAMP #2 MENU (TRACTION SPEED SETTINGS)” on page 35.</a>
<b>DECELERATION RAMP STOP</b>	Used to modify the time interval to fully stop the machine when the drive pedal is released. See <a href="#">“DECELERATION RAMP STOP MENU (TRACTION SPEED SETTINGS)” on page 35.</a>
<b>REVERSE RAMP #1</b>	Used to modify the time interval to switch from forward movement to reverse and vice versa (transfer mode). See <a href="#">“REVERSE RAMP #1 MENU (TRACTION SPEED SETTINGS)” on page 36.</a>

<b>REVERSE RAMP #2</b>	Used to modify the time interval to switch from forward movement to reverse and vice versa (work mode). See <a href="#">“REVERSE RAMP #2 MENU (TRACTION SPEED SETTINGS)” on page 36.</a>
<b>FORWARD MAX SPEED</b>	Used to modify the maximum forward movement speed (transfer mode). See <a href="#">“MAX FORWARD SPEED MENU (TRACTION SPEED SETTINGS)” on page 37.</a>
<b>BACKWARD MAX SPEED</b>	Used to modify the maximum reverse speed. See <a href="#">“MAX BACKWARD SPEED MENU (TRACTION SPEED SETTINGS)” on page 37.</a>
<b>MINIMUM SPEED</b>	Used to modify the speed with the minimum pressure on the drive pedal. See <a href="#">“MINIMUM SPEED MENU (TRACTION SPEED SETTINGS)” on page 38.</a>
<b>MODE1 SPEED</b>	Used to modify the set speed after the activation of the microswitch controlling speed reduction on bends.
<b>MODE1 CURRENT</b>	Used to modify the maximum current that can be supplied after the activation of the microswitch controlling speed reduction on bends. See <a href="#">“MODE1 CURRENT MENU (TRACTION SPEED SETTINGS)” on page 39.</a>
<b>MODE2 SPEED</b>	Used to modify the maximum forward speed (work mode). See <a href="#">“MODE2 SPEED MENU (TRACTION SPEED SETS)” on page 39.</a>
<b>SPEED LEVEL</b>	Used to modify the maximum forward speed (work mode). See <a href="#">“SPEED LEVEL MENU (TRACTION SPEED SETS)” on page 40.</a>

## ACCELERATION RAMP #1 MENU (TRACTION SPEED SETTINGS)

### Traction

Speed Sets

Acceleration Ramp #1:

min:0.5      3.0 [s]      max:5.0



To change the “ACCELERATION RAMP #1” parameter in the Speed Settings menu, proceed as follows:

1. Display the “SPEED SETS” menu. See [“SPEED SETS MENU \(TRACTION SETS\)” on page 32.](#)
2. Use the and buttons to select the “ACCELERATION RAMP #1” screen (see picture alongside).
3. Use the and buttons to select the standby seconds before the machine reaches the maximum speed in transfer mode.

**N.B.:** the selected value will be visible in the text string (1) in the lower part of the screen.

4. Press to confirm.

**N.B.:** the “ACCELERATION RAMP #1” parameter represents the standby time before the machine reaches the maximum speed in transfer mode.

**N.B.:** the “ACCELERATION RAMP #1” parameter is expressed in seconds (s). The numerical value is between a minimum of 0.5 and a maximum of 5.0, with increments of one tenth of a unit.

**N.B.:** the “ACCELERATION RAMP #1” parameter is factory set with the value 3.0.

## ACCELERATION RAMP #2 MENU (TRACTION SPEED SETTINGS)

### Traction

Speed Sets

Acceleration Ramp #2:

4.0 [s]  
min:0.5 max:5.0



To change the “ACCELERATION RAMP #2” parameter in the Speed Settings menu, proceed as follows:

1. Display the “SPEED SETS” menu. See [“SPEED SETS MENU \(TRACTION SETS\)” on page 32.](#)
2. Use the and buttons to select the “ACCELERATION RAMP #2” screen (see picture alongside).
3. Use the and buttons to select the standby seconds before the machine reaches the maximum speed in work mode.

**N.B.:** the selected value will be visible in the text string (1) in the lower part of the screen.

4. Press to confirm.

**N.B.:** the “ACCELERATION RAMP #2” parameter represents the standby time before the machine reaches the maximum speed in work mode.

**N.B.:** the “ACCELERATION RAMP #2” parameter is expressed in seconds (s). The numerical value is between a minimum of 0.5 and a maximum of 5.0, with increments of one tenth of a unit.

**N.B.:** the “ACCELERATION RAMP #2” parameter is factory set with the value 4.0.

## DECELERATION RAMP #1 MENU (TRACTION SPEED SETTINGS)

### Traction

Speed Sets

Deceleration Ramp #1:

1.5 [s]  
min:0.3 max:5.0



To change the “DECELERATION RAMP #1” parameter in the Speed Settings menu, proceed as follows:

1. Display the “SPEED SETS” menu. See [“SPEED SETS MENU \(TRACTION SETS\)” on page 32.](#)
2. Use the and buttons to select the “DECELERATION RAMP #1” screen (see picture alongside).
3. Use the and buttons to select the standby seconds before switching from the current speed to the set speed (with reduced pressure on the drive pedal in transfer mode).

**N.B.:** the selected value will be visible in the text string (1) in the lower part of the screen.

4. Press to confirm.

**N.B.:** the “DECELERATION RAMP #1” parameter represents the standby time before switching from the current speed to the set speed (with reduced pressure on the drive pedal in transfer mode).

**N.B.:** the “DECELERATION RAMP #1” parameter is expressed in seconds (s). The numerical value is between a minimum of 0.3 and a maximum of 5.0, with increments of one tenth of a unit.

**N.B.:** the “DECELERATION RAMP #1” parameter is factory set with the value 1.5.

## DECELERATION RAMP #2 MENU (TRACTION SPEED SETTINGS)

### Traction

Speed Sets

Deceleration Ramp #2:

min:0.3      2.0      [s]      max:5.0



To change the “DECELERATION RAMP #2” parameter in the Speed Settings menu, proceed as follows:

1. Display the “SPEED SETS” menu. See [“SPEED SETS MENU \(TRACTION SETS\)”](#) on page 32.
2. Use the and buttons to select the “DECELERATION RAMP #2” screen (see picture alongside).
3. Use the and buttons to select the standby seconds before switching from the current speed to the set speed (with reduced pressure on the drive pedal in work mode).

**N.B.:** the selected value will be visible in the text string (1) in the lower part of the screen.

4. Press to confirm.

**N.B.:** the “DECELERATION RAMP #2” parameter represents the standby time before switching from the current speed to the set speed (with reduced pressure on the drive pedal in work mode).

**N.B.:** the “DECELERATION RAMP #2” parameter is expressed in seconds (s). The numerical value is between a minimum of 0.3 and a maximum of 5.0, with increments of one tenth of a unit.

**N.B.:** the “DECELERATION RAMP #2” parameter is factory set with the value 2.0.

## DECELERATION RAMP STOP MENU (TRACTION SPEED SETTINGS)

### Traction

Speed Sets

Deceleration Ramp Stop:

min:0.3      2.0      [s]      max:5.0



To change the “DECELERATION RAMP STOP” parameter in the Speed Settings menu, proceed as follows:

1. Display the “SPEED SETS” menu. See [“SPEED SETS MENU \(TRACTION SETS\)”](#) on page 32.
2. Use the and buttons to select the “DECELERATION RAMP STOP” screen (see picture alongside).
3. Use the and buttons to select the standby seconds before the machine stops completely when the drive pedal is released.

**N.B.:** the selected value will be visible in the text string (1) in the lower part of the screen.

4. Press to confirm.

**N.B.:** the “DECELERATION RAMP STOP” parameter represents the standby time for stopping the machine completely when the drive pedal is released.

**N.B.:** the “DECELERATION RAMP STOP” parameter is expressed in seconds (s). The numerical value is between a minimum of 0.3 and a maximum of 5.0, with increments of one tenth of a unit.

**N.B.:** the “DECELERATION RAMP STOP” parameter is factory set with the value 2.0.

## REVERSE RAMP #1 MENU (TRACTION SPEED SETTINGS)

### Traction





Speed Sets

Reverse Ramp #1:

min:0.3      1.0 [s]      max:5.0





To change the “REVERSE RAMP #1” parameter in the Speed Settings menu, proceed as follows:

1. Display the “SPEED SETTINGS” menu. See [“SPEED SETS MENU \(TRACTION SETS\)” on page 32](#).
2. Use the  and  buttons to select the “REVERSE RAMP #1” screen (see picture alongside).
3. Use the  and  buttons to select the standby seconds before switching from forward movement to reverse and vice versa (transfer mode).

 **N.B.:** the selected value will be visible in the text string (1) in the lower part of the screen.

4. Press  to confirm.

 **N.B.:** the “REVERSE RAMP #1” parameter represents the standby time for switching from forward movement to reverse and vice versa (transfer mode).

 **N.B.:** the “REVERSE RAMP #1” parameter is expressed in seconds (s). The numerical value is between a minimum of 0.3 and a maximum of 5.0, with increments of one tenth of a unit.

 **N.B.:** the “REVERSE RAMP #1” parameter is factory set with the value 1.0.

## REVERSE RAMP #2 MENU (TRACTION SPEED SETTINGS)

### Traction





Speed Sets

Reverse Ramp #2:

min:0.3      2.0 [s]      max:5.0





To change the “REVERSE RAMP #2” parameter in the Speed Settings menu, proceed as follows:

1. Display the “SPEED SETTINGS” menu. See [“SPEED SETS MENU \(TRACTION SETS\)” on page 32](#).
2. Use the  and  buttons to select the “REVERSE RAMP #2” screen (see picture alongside).
3. Use the  and  buttons to select the standby seconds before switching from forward movement to reverse and vice versa (work mode).

 **N.B.:** the selected value will be visible in the text string (1) in the lower part of the screen.

4. Press  to confirm.

 **N.B.:** the “REVERSE RAMP #2” parameter represents the standby time for switching from forward movement to reverse and vice versa (work mode).

 **N.B.:** the “REVERSE RAMP #2” parameter is expressed in seconds (s). The numerical value is between a minimum of 0.3 and a maximum of 5.0, with increments of one tenth of a unit.

 **N.B.:** the “REVERSE RAMP #2” parameter is factory set with the value 2.0.

## MAX FORWARD SPEED MENU (TRACTION SPEED SETTINGS)

### Traction





Speed Sets

Forward Max Speed:

min:50 100 [%] max:100

1

To change the “MAX FORWARD SPEED” parameter in the Speed Settings menu, proceed as follows:

1. Display the “SPEED SETTINGS” menu. See [“SPEED SETS MENU \(TRACTION SETS\)” on page 32.](#)
2. Use the  and  buttons to select the “MAX FORWARD SPEED” screen (see picture alongside).
3. Use the  and  buttons to select the maximum speed that can be reached by the machine during forward movements (transfer mode).

 **N.B.:** the selected value will be visible in the text string (1) in the lower part of the screen.

4. Press  to confirm.

 **N.B.:** the “MAX FORWARD SPEED” parameter is the maximum speed the machine can reach during forward movement.

 **N.B.:** the “MAX FORWARD SPEED” parameter is expressed as a percentage (%) of the maximum speed that can be reached in TRANSFER mode. The numerical value is between a minimum of 50 and a maximum of 100, with increments of two units.

 **N.B.:** the “MAX FORWARD SPEED” parameter is factory set at 100.

## MAX BACKWARD SPEED MENU (TRACTION SPEED SETTINGS)

### Traction





Speed Sets

BACKWARD Max Speed:

min:50 50 [%] max:100

1

To change the “MAX BACKWARD SPEED” parameter in the Speed Settings menu, proceed as follows:

1. Display the “SPEED SETS” menu. See [“SPEED SETS MENU \(TRACTION SETS\)” on page 32.](#)
2. Use the  and  buttons to select the “MAX BACKWARD SPEED” screen (see picture alongside).
3. Use the  and  buttons to select the maximum speed that can be reached by the machine in reverse.

 **N.B.:** the selected value will be visible in the text string (1) in the lower part of the screen.

4. Press  to confirm.

 **N.B.:** the “MAX BACKWARD SPEED” parameter is the maximum speed the machine can reach in reverse.

 **N.B.:** the “MAX BACKWARD SPEED” parameter is expressed as a percentage (%) of the MAX FORWARD SPEED. The numerical value is between a minimum of 50 and a maximum of 100, with increments of two units.

 **N.B.:** the “MAX BACKWARD SPEED” parameter is factory set at 50.

## MINIMUM SPEED MENU (TRACTION SPEED SETTINGS)

### Traction

Speed Sets

Minimum Speed:

min:0 10 [%] max:100



To change the “MINIMUM SPEED” parameter in the Speed Settings menu, proceed as follows:

1. Display the “SPEED SETS” menu. See [“SPEED SETS MENU \(TRACTION SETS\)” on page 32](#).
2. Use the and buttons to select the “MINIMUM SPEED” screen (see picture alongside).
3. Use the and buttons to select the speed variation value after the minimum pressure on the drive pedal.

**N.B.:** the selected value will be visible in the text string (1) in the lower part of the screen.

4. Press to confirm.

**N.B.:** the “MINIMUM SPEED” parameter represents the speed variation value after the minimum pressure on the drive pedal.

**N.B.:** the “MINIMUM SPEED” parameter is expressed as a percentage (%) of the MAX FORWARD SPEED. The numerical value is between a minimum of 0 and a maximum of 100, with increments of two units.

**N.B.:** the “MINIMUM SPEED” parameter is factory set at 10.

## MODE1 SPEED MENU (TRACTION SPEED SETS)

### Traction

Speed Sets

Mode1 Speed:

min:0 70 [%] max:100



To change the “MODE1 SPEED” parameter in the Speed Settings menu, proceed as follows:

1. Display the “SPEED SETS” menu. See [“SPEED SETS MENU \(TRACTION SETS\)” on page 32](#).
2. Use the and buttons to select the “MODE1 SPEED” screen (see picture alongside).
3. Use the and buttons to select the set speed after the activation of the microswitch controlling speed reduction on bends.

**N.B.:** the selected value will be visible in the text string (1) in the lower part of the screen.

4. Press to confirm.

**N.B.:** the “MODE1 SPEED” parameter represents the set speed after the activation of the microswitch controlling speed reduction on bends.

**N.B.:** the “MODE1 SPEED” parameter is expressed as a percentage (%) of the MAX FORWARD SPEED. The numerical value is between a minimum of 0 and a maximum of 100, with increments of two units.

**N.B.:** the “MODE1 SPEED” parameter is factory set at 70.

## MODE1 CURRENT MENU (TRACTION SPEED SETTINGS)

### Traction





Speed Sets

Mode1 Current:

min:10      50      [A]      max:100

1

To change the “MODE1 CURRENT” parameter in the Speed Settings menu, proceed as follows:

1. Display the “SPEED SETS” menu. See [“SPEED SETS MENU \(TRACTION SETS\)” on page 32.](#)
2. Use the  and  buttons to select the “MODE1 CURRENT” screen (see picture alongside).
3. Use the  and  buttons to select the value of the current drawn by the traction motor after the activation of the microswitch controlling speed reduction on bends.

 **N.B.:** the selected value will be visible in the text string (1) in the lower part of the screen.

4. Press  to confirm.

 **N.B.:** the “MODE1 CURRENT” parameter represents the value of the current drawn by the traction motor after the activation of the microswitch controlling speed reduction on bends.

 **N.B.:** the “MODE1 CURRENT” parameter is expressed in ampere (A). The numerical value is between a minimum of 10 and a maximum of 100, with increments of two units.

 **N.B.:** the “MODE1 CURRENT” parameter is factory set at 50.

## MODE2 SPEED MENU (TRACTION SPEED SETS)

### Traction





Speed Sets

Mode2 Speed:

min:10      100      [%]      max:100

1

To change the “MODE2 SPEED” parameter in the Speed Settings menu, proceed as follows:

1. Display the “SPEED SETS” menu. See [“SPEED SETS MENU \(TRACTION SETS\)” on page 32.](#)
2. Use the  and  buttons to select the “MODE2 SPEED” screen (see picture alongside).
3. Use the  and  buttons to select the maximum speed that can be reached by the machine during forward movements (work mode).

 **N.B.:** the selected value will be visible in the text string (1) in the lower part of the screen.

4. Press  to confirm.

 **N.B.:** the “MODE2 SPEED” parameter is the maximum speed the machine can reach during forward movements (work mode).

 **N.B.:** the “MODE2 SPEED” parameter is expressed as a percentage (%) of the MAX FORWARD SPEED. The numerical value is between a minimum of 10 and a maximum of 100, with increments of two units.

 **N.B.:** the “MODE2 SPEED” parameter is factory set at 100.

## SPEED LEVEL MENU (TRACTION SPEED SETS)

### Traction





Speed Sets

Speed level #1/3:

40 [%]  
min:10 max:100



To change the “SPEED LEVEL” parameter in the Speed Settings menu, proceed as follows:

1. Display the “SPEED SETS” menu. See [“SPEED SETS MENU \(TRACTION SETS\)” on page 32.](#)
2. Use the  and  buttons to select the “SPEED LEVEL” screen (see picture alongside).
3. Use the  and  buttons to select the maximum forward speed that can be reached by the machine (work mode).

**i** **N.B.:** the selected value will be visible in the text string (1) in the lower part of the screen.

4. Press  to confirm.

**i** **N.B.:** the “SPEED LEVEL” parameters represent the forward speed of the machine when working.

**i** **N.B.:** the “SPEED LEVEL” parameters are expressed as a percentage (%) of MODE2 SPEED. The numerical value is between a minimum of 10 and a maximum of 100, with increments of two units.

**i** **N.B.:** the “SPEED LEVEL” parameters are set to the following numbers in the factory:



- SPEED LEVEL #1= 40
- SPEED LEVEL #2= 70
- SPEED LEVEL #3= 100

## SPEED REF MENU (TRACTION SETTINGS)

### Traction

Speed Ref

To view the “SPEED REF” menu, proceed as follows:

1. View the “TRACTION SETTINGS” menu. See [“TRACTION SETTINGS MENU \(SETTINGS\)” on page 32.](#)
2. Use the  and  buttons to select the “Speed settings” screen (see picture alongside), then press  to confirm.

The following personalised selections can be made on the Speed Ref menu screen:

<b>SIGNAL MIN POSITION</b>	Used to modify the minimum voltage of the drive pedal potentiometer (idle mode). See <a href="#">“MIN POSITION SIGNAL MENU (TRACTION SPEED REF)” on page 41.</a>
<b>SIGNAL MAX POSITION</b>	Used to modify the minimum voltage of the drive pedal potentiometer (maximum pressure mode). See <a href="#">“MAX POSITION SIGNAL MENU (TRACTION SPEED REF)” on page 41.</a>
<b>SIGNAL DEAD BAND</b>	Used to modify the inactivation voltage of the drive pedal potentiometer. See <a href="#">“DEAD BAND SIGNAL MENU (TRACTION SPEED REF)” on page 42.</a>
<b>SIGNAL MID POS</b>	Used to select the intermediate voltage of the potentiometer (when active). See <a href="#">“MID SIGNAL MENU (TRACTION SPEED REF)” on page 42.</a>

## MIN POSITION SIGNAL MENU (TRACTION SPEED REF)

### Traction

Speed Ref

Signal Min Position:

min:0      0.7 [V]      max:10



To change the “MIN POSITION SIGNAL” parameter in the Speed Ref menu, proceed as follows:

1. Display the “SPEED REF” menu. See [“SPEED REF MENU \(TRACTION SETTINGS\)” on page 40.](#)
2. Use the and buttons to select the “MIN POSITION SIGNAL” screen (see picture alongside).
3. Use the and buttons to select the value of the voltage drawn by the drive pedal (idle mode).

**N.B.:** the selected value will be visible in the text string (1) in the lower part of the screen.

4. Press to confirm.

**N.B.:** the “MIN POSITION SIGNAL” represents the value of the voltage drawn by the drive pedal (idle mode).

**N.B.:** the “MIN POSITION SIGNAL” parameter is expressed in Volt (V). The numerical value is between a minimum of 0 and a maximum of 10, in increments of one tenth of a unit.

**N.B.:** the “MIN POSITION SIGNAL” parameter is factory set at 0.7.

## MAX POSITION SIGNAL MENU (TRACTION SPEED REF)

### Traction

Speed Ref

Signal Max Position:

min:0      3.3 [V]      max:15



To change the “MAX POSITION SIGNAL” parameter in the Speed Ref menu, proceed as follows:

1. Display the “SPEED REF” menu. See [“SPEED REF MENU \(TRACTION SETTINGS\)” on page 40.](#)
2. Use the and buttons to select the “MAX POSITION SIGNAL” screen (see picture alongside).
3. Use the and buttons to select the value of the voltage drawn by the drive pedal (work mode, maximum stroke).

**N.B.:** the selected value will be visible in the text string (1) in the lower part of the screen.

4. Press to confirm.

**N.B.:** the “MAX POSITION SIGNAL” represents the value of the voltage drawn by the drive pedal (work mode, maximum stroke).

**N.B.:** the “MAX POSITION SIGNAL” parameter is expressed in Volt (V). The numerical value is between a minimum of 0 and a maximum of 10, in increments of one tenth of a unit.

**N.B.:** the “MAX POSITION SIGNAL” parameter is factory set at 3.3.

## DEAD BAND SIGNAL MENU (TRACTION SPEED REF)

### Traction

Speed Ref



Signal Dead Band:



min:0      50      [V]      max:500



To change the “DEAD BAND SIGNAL” parameter in the Speed Ref menu, proceed as follows:

1. Display the “SPEED REF” menu. See [“SPEED REF MENU \(TRACTION SETTINGS\)” on page 40.](#)

2. Use the  and  buttons to select the “DEAD BAND SIGNAL” screen (see picture alongside).

3. Use the  and  buttons to select the value of the dead band of the potentiometer signal.

 **N.B.:** the selected value will be visible in the text string (1) in the lower part of the screen.

4. Press  to confirm.

 **N.B.:** the “DEAD BAND SIGNAL” parameter represents the value of the voltage drawn by the drive pedal in its idle state. Beyond this voltage value, the drive pedal will start working.

 **N.B.:** the “DEAD BAND SIGNAL” parameter is expressed in millivolt (mV). The numerical value is between a minimum of 0 and a maximum of 500, in increments of ten units.

 **N.B.:** the “DEAD BAND SIGNAL” parameter is factory set at 50.

## MID SIGNAL MENU (TRACTION SPEED REF)

### Traction

Speed Ref



Signal Mid.:



min:0      2.0      [V]      max:10



To change the “DEAD BAND SIGNAL” parameter in the Speed Ref menu, proceed as follows:

1. Display the “SPEED REF” menu. See [“SPEED REF MENU \(TRACTION SETTINGS\)” on page 40.](#)

2. Use the  and  buttons to select the “MID SIGNAL” screen (see picture alongside).

3. Use the  and  buttons to select the value of the intermediate voltage of the potentiometer (when active).

 **N.B.:** the selected value will be visible in the text string (1) in the lower part of the screen.

4. Press  to confirm.

 **N.B.:** the “MID SIGNAL” parameter represents the value of the intermediate voltage of the potentiometer when it is active.

 **N.B.:** the “MID SIGNAL” parameter is expressed in Volt (V). The numerical value is between a minimum of 0 and a maximum of 500, in increments of one tenth of a unit.



 **N.B.:** the “MID SIGNAL” parameter is factory set at 2.0.

## MOTOR SETTINGS MENU (TRACTION SETTINGS)

### Traction

#### Motor Sets

To view the “MOTOR SETTINGS” menu, proceed as follows:

1. View the “TRACTION SETTINGS” menu. See [“TRACTION SETTINGS MENU \(SETTINGS\)” on page 32.](#)
2. Use the  and  buttons to select the “Speed settings” screen (see picture alongside), then press  to confirm.

The following personalised selections can be made on the Monitor settings menu screen:

<b>BOOST CURRENT</b>	Used to regulate the maximum current that the function board can supply to the traction motor for a specific period of time. See <a href="#">“CURRENT BOOST MENU (TRACTION MOTOR SETTINGS)” on page 43.</a>
<b>BOOST TIME</b>	Used to regulate the maximum time in which the board can supply boost current to the traction motor. See <a href="#">“BOOST TIME MENU (TRACTION MOTOR SETTINGS)” on page 44.</a>

## CURRENT BOOST MENU (TRACTION MOTOR SETTINGS)



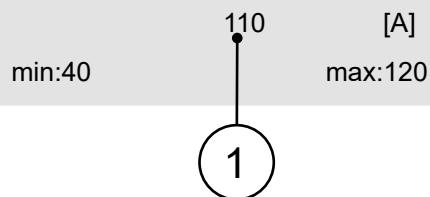

### Traction

#### Motor Sets

Boost Current:





To change the “CURRENT BOOST” parameter in the Motor Settings menu, proceed as follows:

1. Display the “MOTOR SETTINGS” menu. See [“MOTOR SETTINGS MENU \(TRACTION SETTINGS\)” on page 43.](#)
2. Use the  and  buttons to select the “CURRENT BOOST” screen (see picture alongside).
3. Use the  and  buttons to select the value of the maximum current that the function board can supply to the traction motor for a specific period of time.

 **N.B.:** the selected value will be visible in the text string (1) in the lower part of the screen.

4. Press  to confirm.

 **N.B.:** the “CURRENT BOOST” parameter is the value of the maximum current that the function board can supply to the traction motor for a specific period of time.

 **N.B.:** the “CURRENT BOOST” parameter is expressed in Volt (V). The numerical value is between a minimum of 40 and a maximum of 150, in increments of five units.

 **N.B.:** the “CURRENT BOOST” parameter is factory set at 110.

## BOOST TIME MENU (TRACTION MOTOR SETTINGS)



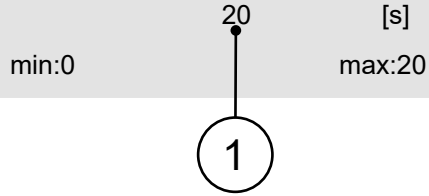

### Traction

Motor Sets

Boost Time:



To change the “BOOST TIME” parameter in the Motor Settings menu, proceed as follows:

1. Display the “MOTOR SETTINGS” menu. See [“MOTOR SETTINGS MENU \(TRACTION SETTINGS\)” on page 43.](#)
2. Use the  and  buttons to select the “BOOST TIME” screen (see picture alongside).
3. Use the  and  buttons to select the maximum time in which the function board can supply boost current to the traction motor.

**i** **N.B.:** the selected value will be visible in the text string (1) in the lower part of the screen.

4. Press  to confirm.

**i** **N.B.:** the “BOOST TIME” parameter is the maximum time in which the board can supply boost current to the traction motor.

**i** **N.B.:** the “BOOST TIME” parameter is expressed in seconds (s). The numerical value is between a minimum of 0 and a maximum of 20, in increments of five units.



**i** **N.B.:** the “BOOST TIME” parameter is factory set at 20.

## MONITOR MODE MENU (SETTINGS)

### -SETTINGS-

Monitor mode...

To view the “MONITOR MODE” menu, proceed as follows:

1. Display the “SETTINGS MENU” menu. See [“SETTINGS MENU” on page 12.](#)
2. Use the  and  buttons to select the “MONITOR MODE” screen (see picture alongside), then press  to confirm.

**i** **N.B.:** in the parameters menu, the display is only shown in English.

The following parameters can be selected on the Monitor mode menu screen:

<b>Monitor Sets</b>	Used to view the status of the main machine components on the control display (in place of the partial hour meter).
---------------------	---

## MONITOR SETTINGS MENU (MONITOR MODE)





### Monitor Sets

No\_Monitor

[Sel.item to display]

1

To change the “MONITOR SETTINGS” parameter in the Monitor Mode menu, proceed as follows:

1. View the “MOTOR SETTINGS” menu. See [“MONITOR MODE MENU \(SETTINGS\)” on page 44.](#)
2. Use the  and  buttons to select the “MONITOR SETTINGS” screen (see picture alongside).
3. Use the  and  buttons to select the parameter you want to view on the control display (in place of the partial hour meter).

 **N.B.:** the selected value will be visible in the text string (1) in the lower part of the screen.

4. Press  to confirm.

The following parameters can be selected on the Monitor mode menu screen:

DESCRIPTION	UNIT	DESCRIPTION
<b>No Monitor</b>		If this parameter is selected, the control display will be the standard one
<b>Function Inputs</b>	V	If this parameter is selected, the control display will show the drive pedal potentiometer voltage in place of the hour meter
<b>Keyboard</b>		If this parameter is selected, the procedure to test the control panel membrane buttons will be run. See “CONTROL PANEL” present in the “USE AND MAINTENANCE MANUAL” delivered with the machine documentation
<b>Functions Temp</b>	°C	If this parameter is selected, the control display will show the temperature of the function board in place of the hour meter
<b>Traction Temp</b>	°C	If this parameter is selected, the control display will show the temperature of the traction motor in place of the hour meter
<b>Vacuum Current</b>	A	If this parameter is selected, the control display will show the instantaneous drawn current of the suction motor in place of the hour meter
<b>Brushes Current</b>	A	If this parameter is selected, the control display will show the instantaneous drawn current of the central brush motor in place of the hour meter
<b>Traction Ammeter</b>	A	If this parameter is selected, the control display will show the maximum drawn current of the traction motor in place of the hour meter
<b>Traction Current</b>	A	If this parameter is selected, the control display will show the instantaneous drawn current of the traction motor in place of the hour meter
<b>Traction Voltage</b>	V	If this parameter is selected, the control display will show the drawn voltage of the traction motor in place of the hour meter
<b>Battery</b>	V	If this parameter is selected, the control display will show the voltage supplied by the batteries in place of the hour meter

5. Use the  and  buttons to select the “EXIT” screen.

6. Press  to confirm you want to quit the “SETTINGS” menu.

 **N.B.:** the control display will return to the work screen, but the previously selected parameter will be shown in place of the partial hour meter.

 **N.B.:** to quit the “MONITOR MODE” function, switch the machine off and then back on again.







**FIMAP S.p.A.**

✉ Via Invalidi del Lavoro, 1  
37059 S. Maria di Zevio (VR)

Italy

☎ +39 045 6060491 - 📠 +39 045 6060440

@ [service@fimap.com](mailto:service@fimap.com) 🌐 [www.fimap.com](http://www.fimap.com)